

# PTFE L-SHAPED (TFCL)

KW	HORIZONTAL	COLD (MAXIMUM)	IMMERSION (MAXIMUM)	COIL O.D.
0.5	3.50	40.00	45.00	3.56
1.0	5.00	40.00	45.00	3.56
1.5	7.00	40.00	45.00	3.56
2.0	9.00	40.00	45.00	3.56
2.5	11.00	40.00	45.00	3.56
3.0	12.50	30.00	35.00	3.56
3.5	14.50	15.00	20.00	3.56

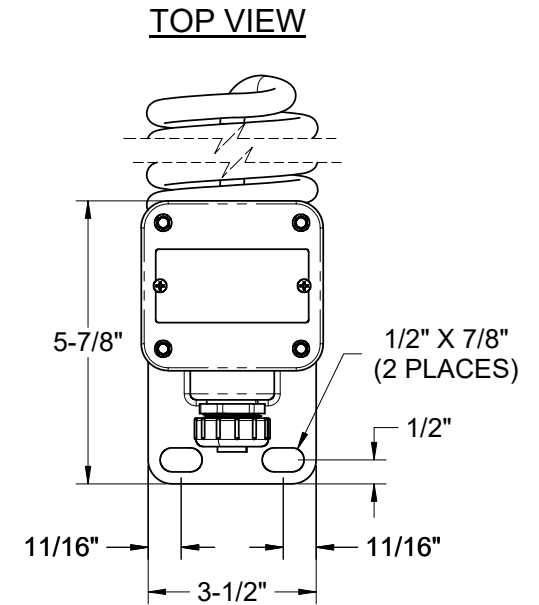
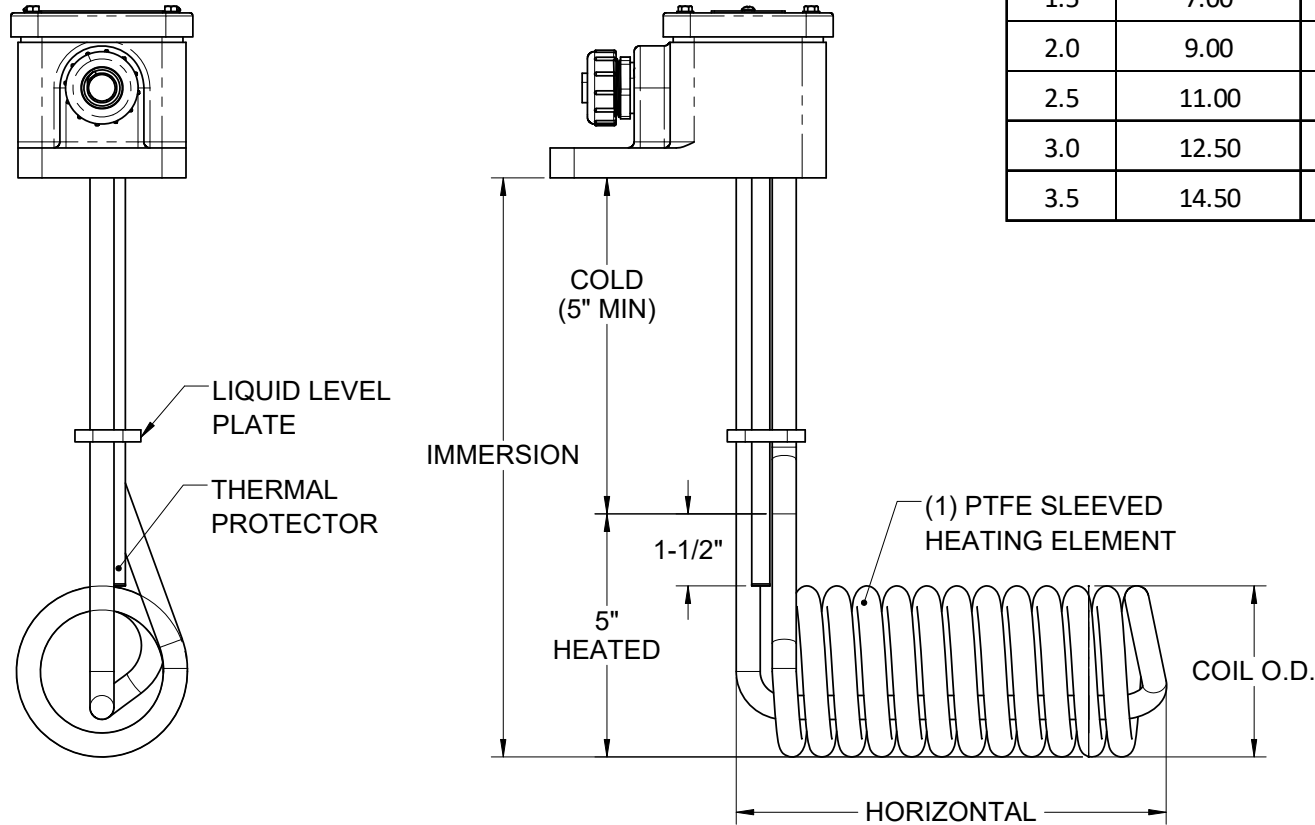

REV	BY	DATE	DESCRIPTION

UNLESS OTHERWISE SPECIFIED  
DIMENSIONS ARE IN INCHES

[mm]  
IN

ANGLES	.XX	.XXX	X/X
±°	±	±	±

**MATERIAL**  
SEE NOTES

**PART NUMBER**  
NA

DRAWN BY	DATE
DLS	1/15/2026

CHECKED BY	DATE

**HEATMAX** 7084 MAPLE ST.  
**HEATERS** MENTOR, OH 44060

**TITLE:**  
SALES, COILED PTFE L-SHAPED HEATER

THE INFORMATION CONTAINED IN THIS DRAWING IS THE SOLE PROPERTY OF GLO-QUARTZ®. ANY REPRODUCTION IN PART OR AS A WHOLE WITHOUT THE WRITTEN PERMISSION OF GLO-QUARTZ® IS PROHIBITED.

INTERPRET GEOMETRIC DIMENSIONS PER ASME Y14.5-2009

DRAWING NUMBER	REVISION	SHEET NO.
13-0261	A	1 OF 1