

MAX-TI: TITANIUM FLANGE HEATERS

ENGINEERED FOR EXTREME CHEMICAL RESISTANCE, THE MAX-TI TITANIUM FLANGE HEATER DELIVERS RELIABLE PERFORMANCE IN SOME OF THE HARSHTEST CORROSIVE ENVIRONMENTS.

QUICK SPECIFICATIONS		CUSTOMIZABLE FEATURES
WATTAGES:	500 - 200,000 Watts	The following are configurable based on application requirements: <ul style="list-style-type: none"> • Wattage and Watt Density • Voltage • Immersion and Cold Lengths • Element Number and Sheath Material • Enclosure Ratings
VOLTAGES:	120 - 600 Volts	
PHASE:	1 & 3 Phase	
FLANGE SIZES:	<ul style="list-style-type: none"> • ANSI Sizes: 3", 4", 6", 8", 10" and 12" 	
ENCLOSURE RATINGS:	Type 1, 4, and 4X Enclosures Available	
ALLOY:	Grade 2 Commercially Pure Titanium	
UL / CSA recognized configurations available Contact us to confirm coverage for your specifications.		

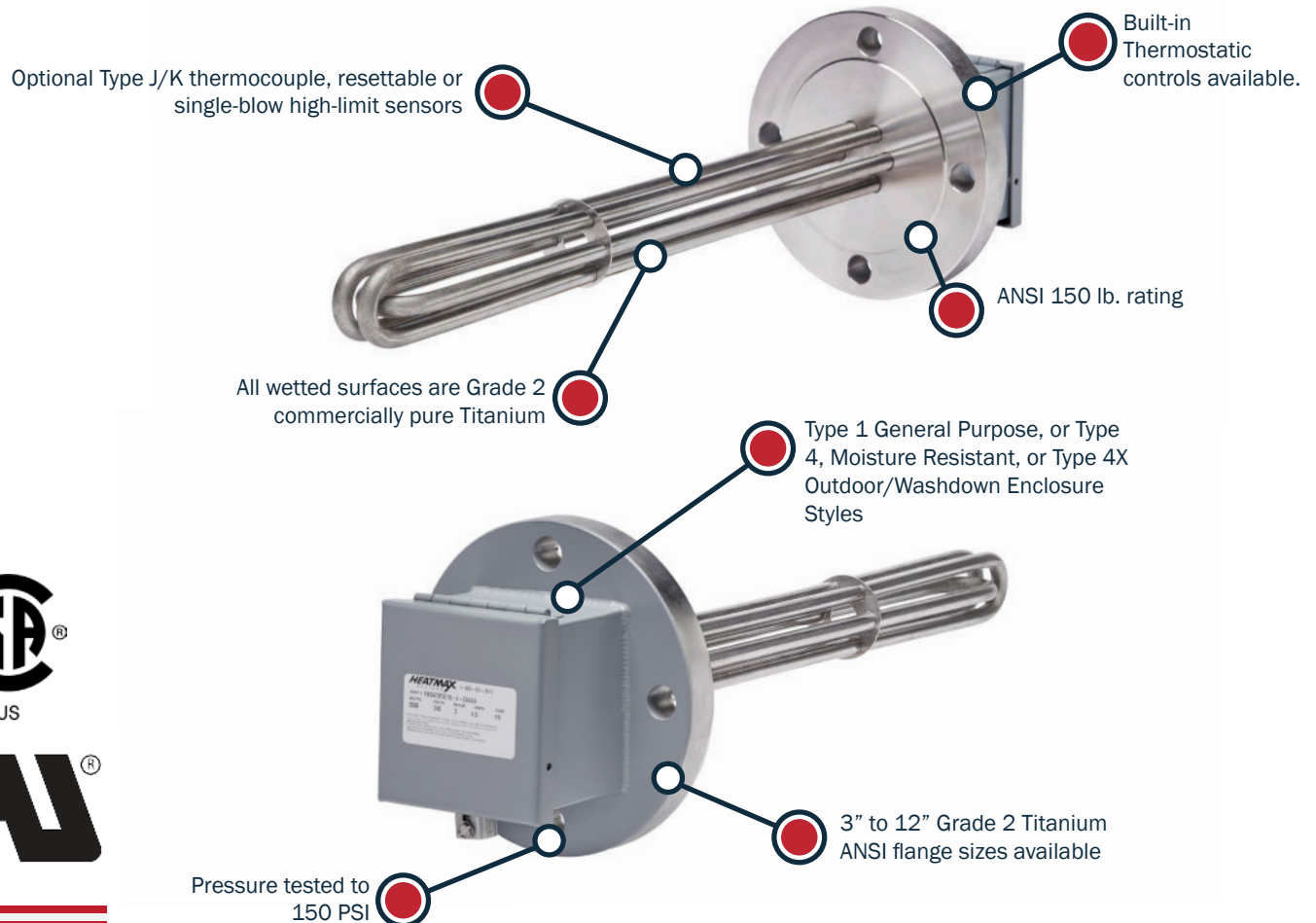

FLANGE REFERENCE DIMENSIONS : ANSI 150 LB.						
FLANGE SIZE *	FLANGE OD	FLANGE THICKNESS	HOLE #	HOLE DIA	COLD ZONE (STD.)	ELEMENT NUMBER
3"	7.5"	.94"	4	3/4"	4"	3 (standard) 6 (max)
4"	9"	.94"	8	3/4"	4"	6 (standard) 6 (max)
6"	11"	1"	8	7/8"	4"	12 (standard) 15 (max)
8"	13.5"	1.125"	8	7/8"	6"	18 (standard) 24 (max)
10"	16"	1.187"	12	1"	6"	27 (standard) 36 (max)
12"	19"	1.25	12	1"	6"	36 (standard) 54 (max)

FLANGE REFERENCE AND STYLES

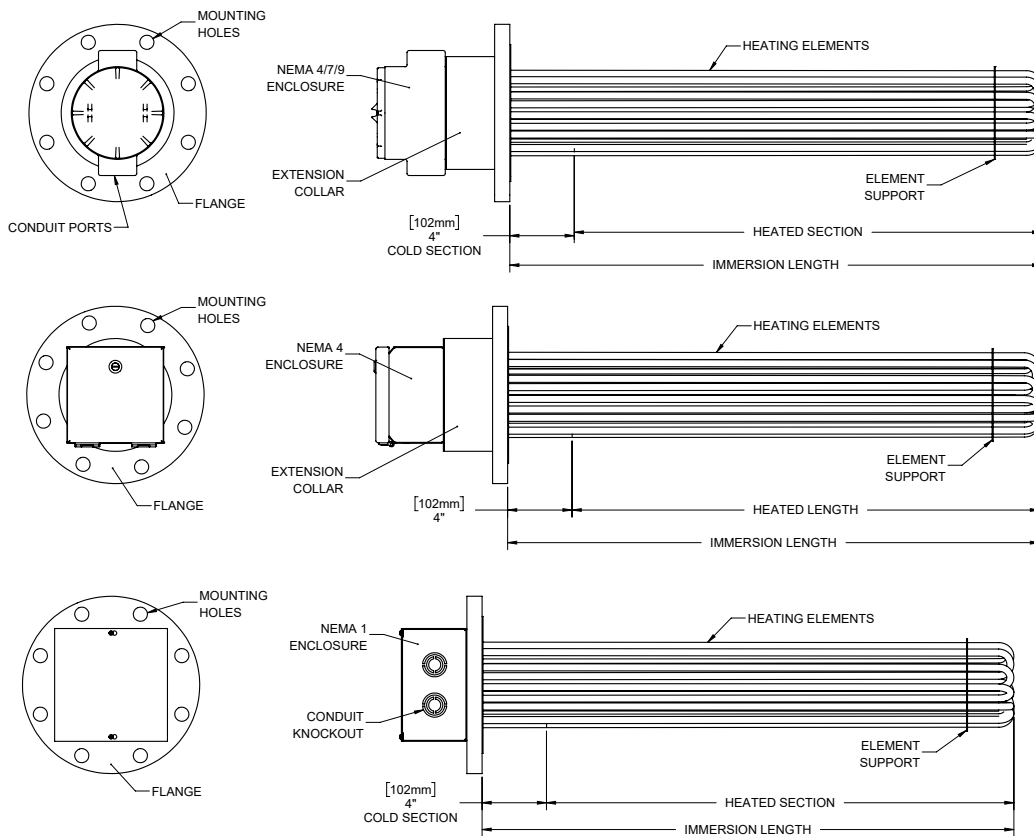

ORDERING AND CONTACT INFO

FOR ORDERS, PLEASE CONTACT US AT: sales@heatmaxheaters.com.
FOR MORE INFO ON OUR PRODUCTS, SEE OUR WEBSITE AT WWW.HEATMAXHEATERS.COM