

HEAT **MAX**



REPRESENTED BY:

**2026 METAL PLATING
PRODUCT CATALOG**

TABLE OF CONTENTS

GENERAL INFORMATION	PG 1
TF SERIES: PTFE HEATERS	PG 2-5
TFL SERIES: L-SHAPED PTFE HEATERS	PG 6-9
TFC SERIES: COILED PTFE HEATERS	PG 10-13
SW SERIES: OVER-THE-SIDE HEATERS	PG 14-21
DT SERIES: DEEP TANK HEATERS	PG 22-23
L SERIES: L-SHAPED HEATERS	PG 24-37
F SERIES: FLANGE HEATERS	PG 38-43
R SERIES: SCREW PLUG HEATERS	PG 44-47
THERMAL PROTECTORS	PG 48-49
COMBINATION CONTROLLERS	PG 50-51
LIQUID LEVEL CONTROLS	PG 52-55
CONTROL ACCESSORIES	PG 56-57
CHEMICAL COMPATIBILITY GUIDE	PG 58-59
WARRANTY AND RETURNS	PG 60-61



ENGINEERED INDUSTRIAL HEATING SOLUTIONS

Built to Order. Designed for Demanding Applications

Heatmax designs and manufactures industrial electric immersion heaters for corrosive, safety-critical, and compliance-driven applications. Since 1952, we have specialized in heaters used in chemical processing, metal finishing, water and wastewater treatment, and OEM equipment where reliability and long-term performance matter.

What We Build

Heatmax manufactures a full range of electric immersion heaters, including:

- Over-the-side heaters for open tanks
- L-shaped immersion heaters designed to rest on the bottom of open tanks
- PTFE-coated heaters for aggressive chemistries
- Flanged and screwplug heaters
- Controls, thermal protection, and level-safety accessories



Additionally, heaters shown in this catalog with the adjacent badge are available with UL certification, providing compliance, safety, and peace of mind.

Customization is Standard

We manufacture our heating elements in-house. This allows us to customize our products to meet specific application requirements or directly replace heaters from other manufacturers. Common configurable parameters include: immersion and cold lengths, voltage and phase (single or three phase), wattage and watt density, materials of construction, thermal protection type, lead wire and conduit length.

How to Use This Catalog

This catalog presents standard configurations and list prices for commonly specified heater designs. Variations in length, voltage, materials or thermal protection may affect pricing. As not all configurations are shown, consult Heatmax for non-standard requirements (see pg. 61). Discounts may be available through authorized resellers and OEM partners. If your application falls outside the configurations shown, our team will assist in selecting or designing the correct heater.

TF SERIES: PTFE HEATERS

The **TF Series PTFE** immersion heaters are designed for heating aggressive acids and caustic solutions where metal-sheathed heaters are unsuitable. Featuring thick wall, American-made PTFE encapsulation and conservative watt densities, the TF Series provides reliable, corrosion-resistant heating for metal finishing and chemical processing applications.

Choose the TF Series when:

- The process solution is highly corrosive
- Long heater life is prioritized over compact size
- Vertical installation into an open topped tank is available

TF SERIES REFERENCE DIMENSIONS

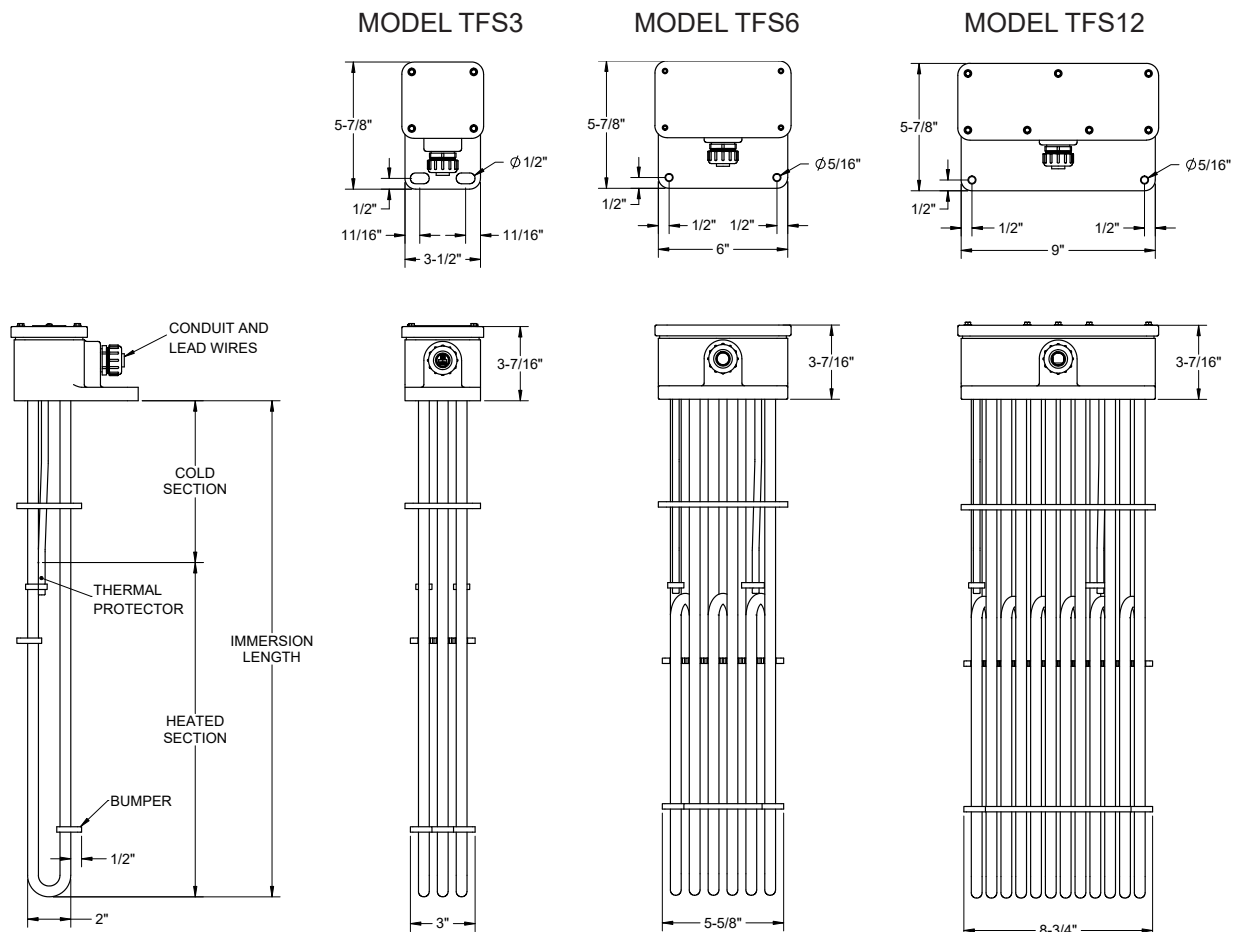

TF SERIES: PTFE HEATERS

PRODUCT FEATURES

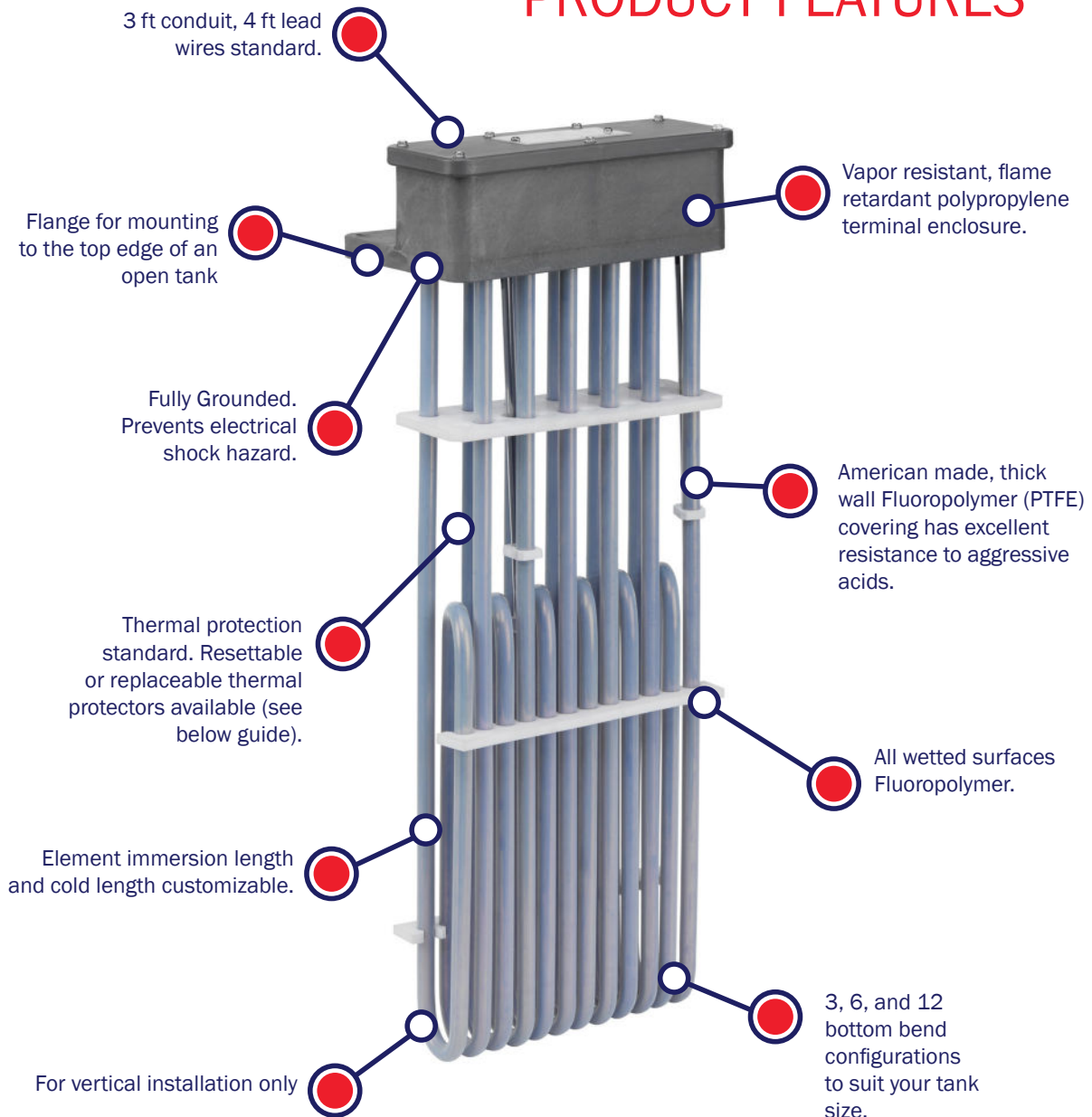

Thermal Protector Guide		
TYPE	MODEL NUMBER	TEMP RANGE
Replaceable Thermal Protectors	T1	Up to 180°F
Resettable Thermal Protectors	T2	Up to 180°F



TF SERIES: PTFE HEATERS



TFS3 PTFE HEATERS					
PART NUMBER	SPECIFICATIONS				
	Volts (1-PH)	Watts	Immersion Length	Heated Length	Cold Length
TFS3-3-05AX11-6-T*	120	500	11"	5"	6"
TFS3-3-1AX17-8-T*	120	1,000	17"	9"	8"
TFS3-3-1EX17-8-T*	240				
TFS3-3-2AX29-8-T*	120	2,000	29"	21"	8'
TFS3-3-2EX29-8-T*	240				
TFS3-3-2MX29-8-T*	480				
TFS3-3-3EX35-7-T*	240	3,000	35"	28"	7"
TFS3-3-3MX35-7-T*	480				
TFS3-3-4EX47-9-T*	240	4,000	47"	38"	9"
TFS3-3-4MX47-9-T*	480				
TFS3-3-5EX59-12-T*	240	5,000	59"	47"	12"
TFS3-3-5MX59-12-T*	480				
TFS3-3-6EX68-13-T*	240	6,000	68"	55"	13"
TFS3-3-6MX68-13-T*	480				

*Specify thermal protection desired, see page (48-49). Please note PTFE should not exceed 212 °F.

**Polypropylene Guards are recommended for PTFE Heaters. Heatmax Guards are polypropylene and permanently attached to heater. (Not suitable for Chromic Acid).

Above Heaters coded for Single-Phase. Three-Phase options available at no extra charge. Remove "x" to make part number 3-phase.



TFS6 PTFE HEATERS					
PART NUMBER	SPECIFICATIONS				
	Volts (3-PH)	Watts	Immersion Length	Heated Length	Cold Length
TFS6-3-1A15-7-T*	120	1,000	15"	8"	7"
TFS6-3-1M15-7-T*	480				
TFS6-3-2E17-8-T*	240	2,000	17"	9"	8"
TFS6-3-2M17-8-T*	480				
TFS6-3-3E23-8-T*	240	3,000	23"	15"	8"
TFS6-3-3M23-8-T*	480				
TFS6-3-4E29-8-T*	240	4,000	29"	21'	8"
TFS6-3-4M29-8-T*	480				
TFS6-3-5E32-7-T*	240	5,000	32"	25'	7"
TFS6-3-5M32-7-T*	480				
TFS6-3-6E35-7-T*	240	6,000	35"	28"	7"
TFS6-3-6M35-7-T*	480				
TFS6-3-7E43-8-T*	240	7,000	43"	35"	8"
TFS6-3-7M43-8-T*	480				
TFS6-3-8E47-9-T*	240	8,000	47"	38"	9"
TFS6-3-8M47-9-T*	480				
TFS6-3-9E52-9-T*	240	9,000	52"	43"	9"
TFS6-3-9M52-9-T*	480				
TFS6-3-10E59-12-T*	240	10,000	59"	47"	12"
TFS6-3-10M59-12-T*	480				
TFS6-6-12E68-13-T*	240	12,000	68"	55"	13"
TFS6-6-12M68-13-T*	480				

*Specify thermal protection desired, see page (48-49). Please note PTFE should not exceed 212 °F.

**Polypropylene Guards are recommended for PTFE Heaters. Heatmax Guards are polypropylene and permanently attached to heater. (Not suitable for Chromic Acid).

Above Heaters coded for Three Phase. Single Phase is available for some options.

TF SERIES: PTFE HEATERS



TFS12 PTFE HEATERS					
PART NUMBER	SPECIFICATIONS				
	Volts (3-PH)	Watts	Immersion Length	Heated Length	Cold Length
TFS12-3-1.5A15-7-T*	120	1,500	15	8	7
TFS12-3-1.5E15-7-T*	240				
TFS12-3-3E15-7-T*	240	3,000	15	8	7
TFS12-3-3M15-7-T*	480				
TFS12-3-4E18-8-T*	240	4,000	18	10	8
TFS12-3-4M18-8-T*	480				
TFS12-3-5E21-8-T*	240	5,000	21	13	8
TFS12-3-5M21-8-T*	480				
TFS12-3-6E23-8-T*	240	6,000	23	15	8
TFS12-3-6M23-8-T*	480				
TFS12-3-8E30-10-T*	240	8,000	30	20	10
TFS12-3-8M30-10-T*	480				
TFS12-3-9E30-8-T*	240	9,000	30	22	8
TFS12-3-9M30-8-T*	480				
TFS12-6-12E37-8-T*	240	12,000	37	29	8
TFS12-6-12M37-8-T*	480				
TFS12-6-15E44-8-T*	240	15,000	44	36	8
TFS12-6-15M44-8-T*	480				
TFS12-6-18E50-8-T*	240	18,000	50	42	8
TFS12-6-18M50-8-T*	480				
TFS12-6-21M58-8-T*	480	21,000	58	50	8

*Specify thermal protection desired, see page (48-49). Please note PTFE should not exceed 212 °F.

**Polypropylene Guards are recommended for PTFE Heaters.

Heatmax Guards are polypropylene and permanently attached to heater. (Not suitable for Chromic Acid).

Above Heaters coded for Three Phase. Single Phase is available for some options.

Note: Additional wattages, voltages, and lengths available.

TFL SERIES: PTFE HEATERS

The **TFL Series L-shaped PTFE** immersion heaters are designed for aggressive chemical applications where corrosion resistance and low watt density are critical, and where tank geometry or obstructions require a bottom-resting heater configuration.

Choose the TFL Series when:

- The process solution is highly corrosive and requires PTFE wetted surfaces
- Shallow tanks / limited sidewall clearance require L-shaped designs
- Where more kW and a faster heat up time is needed

TFL SERIES REFERENCE DIMENSIONS

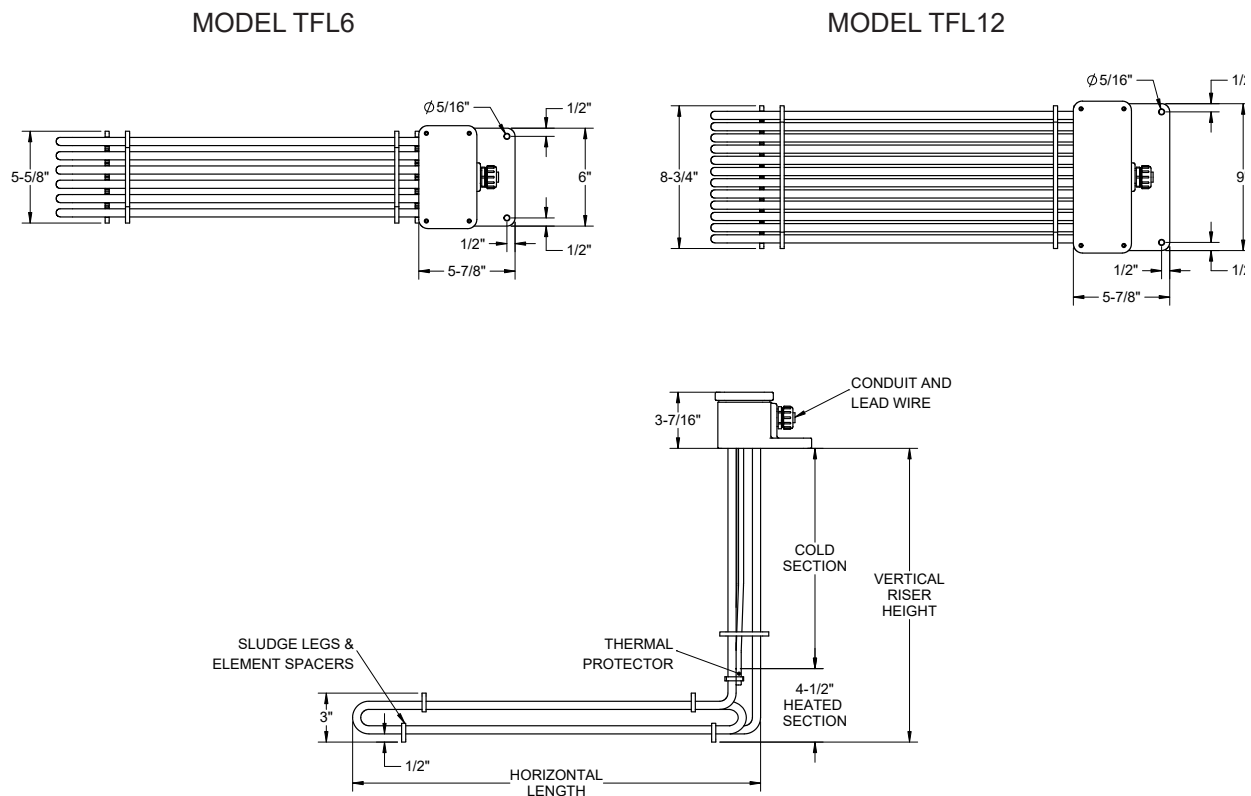

TFL SERIES: PTFE HEATERS

PRODUCT FEATURES

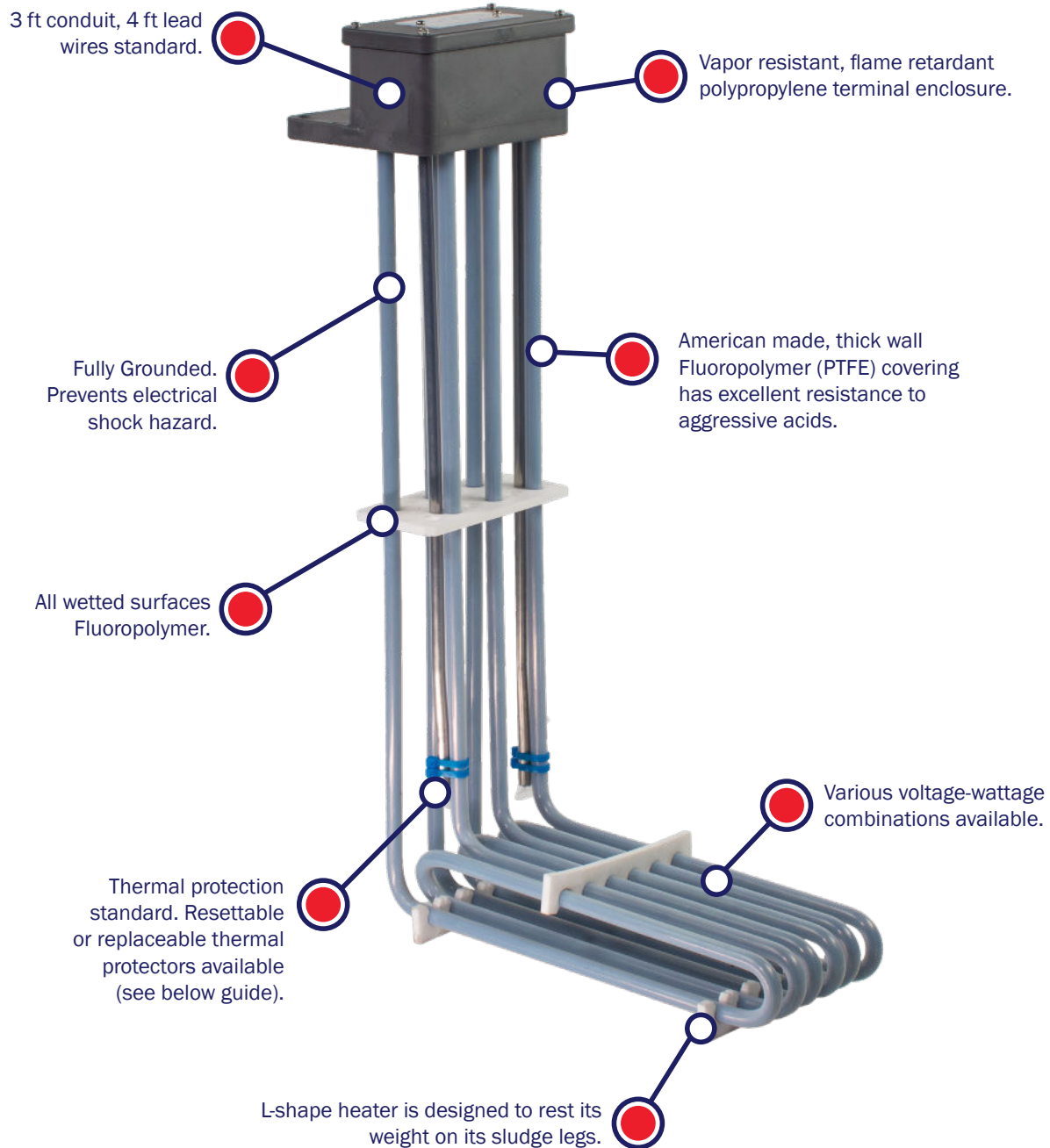

Thermal Protector Guide		
TYPE	MODEL NUMBER	TEMP RANGE
Replaceable Thermal Protectors	T1	Up to 180°F
Resettable Thermal Protectors	T2	Up to 180°F



TFL SERIES: PTFE HEATERS



TFL6 PTFE HEATERS					
PART NUMBER	SPECIFICATIONS				
	Volts (3-PH)	Watts	Vertical Length	Max Vertical Length	Horizontal Length
TFL6-3-05A8R18-T*	120	500	18"	107"	8"
TFL6-3-05E8R18-T*	240			107"	8"
TFL6-3-1A8R18-T*	120	1,000		107"	8"
TFL6-3-1E8R18-T*	240			96"	11"
TFL6-3-2E11R18-T*	240	2,000		96"	15"
TFL6-3-2M11R18-T*	480			84"	20"
TFL6-3-3E15R18-T*	240	3,000		80"	25"
TFL6-3-3M15R18-T*	480			72"	30"
TFL6-3-4E20R18-T*	240	4,000		60"	35"
TFL6-3-4M20R18-T*	480			50"	40"
TFL6-3-5E25R18-T*	240	5,000		45"	42"
TFL6-3-5M25R18-T*	480				
TFL6-3-6E30R18-T*	240	6,000			
TFL6-3-6M30R18-T*	480				
TFL6-3-7E35R18-T*	240	7,000			
TFL6-3-7M35R18-T*	480				
TFL6-3-8E40R18-T*	240	8,000			
TFL6-3-8M40R18-T*	480				
TFL6-3-9E42R18-T*	240	9,000			
TFL6-3-9M42R18-T*	480				

*Specify thermal protection desired, see page (48-49). Please note PTFE should not exceed 212°F.

**Guard not pictured. Polypropylene Guards are recommended for PTFE Heaters. Heatmax Guards are polypropylene and permanently attached to heater. (Not suitable for Chromic Acid).

Above Heaters coded for Three-Phase. Single Phase options available. Consult Factory.

Note: Additional wattages, voltages, and lengths available.

TFL SERIES: PTFE HEATERS



TFL12 PTFE HEATERS					
PART NUMBER	SPECIFICATIONS				
	Volts (3-PH)	Watts	Vertical Length	Max Vertical Length	Horizontal Length
TFL12-6-2E8R18-T*	240	2,000	18"	107"	8"
TFL12-6-2M8R18-T*	480			105"	9"
TFL12-6-3E9R18-T*	240	3,000		96"	11"
TFL12-6-3M9R18-T*	480			95"	14"
TFL12-6-4E11R18-T*	240	4,000		93"	15"
TFL12-6-4M11R18-T*	480			87"	18"
TFL12-6-5E14R18-T*	240	5,000		82"	20"
TFL12-6-5M14R18-T*	480			74"	24"
TFL12-6-6E15R18-T*	240	6,000		72"	25"
TFL12-6-6M15R18-T*	480			62"	30"
TFL12-6-7E18R18-T*	240	7,000		52"	35"
TFL12-6-7M18R18-T*	480			42"	40"
TFL12-6-8E20R18-T*	240	8,000		38"	42"
TFL12-6-8M20R18-T*	480				
TFL12-6-9E24R18-T*	240	9,000			
TFL12-6-9M24R18-T*	480				
TFL12-6-10E25R18-T*	240	10,000			
TFL12-6-10M25R18-T*	480				
TFL12-6-12E30R18-T*	240	12,000			
TFL12-6-12M30R18-T*	480				
TFL12-6-14E35R18-T*	240	14,000			
TFL12-6-14M35R18-T*	480				
TFL12-6-16E40R18-T*	240	16,000			
TFL12-6-16M40R18-T*	480				
TFL12-6-18E42R18-T*	240	18,000			
TFL12-6-18M42R18-T*	480				

*Specify thermal protection desired, see page (48-49). Please note PTFE should not exceed 212° F.

**Guard not pictured. Polypropylene Guards are recommended for PTFE Heaters. Heatmax Guards are polypropylene and permanently attached to heater. (Not suitable for Chromic Acid).

Above Heaters coded for Three-Phase. Single Phase options available. Consult Factory.

Note: Additional wattages, voltages, and lengths available.

TFC SERIES: COILED PTFE HEATERS

The **TFC Coiled PTFE** immersion heaters are designed for corrosive chemical applications where tank space is limited and a compact design is called for. Ideal for low liquid levels, small tanks, and laboratory applications.

Choose the TFC Series when:

- A PTFE-encapsulated heater is needed for aggressive acids or caustic solutions.
- Tank space is limited and a compact heater design is required.

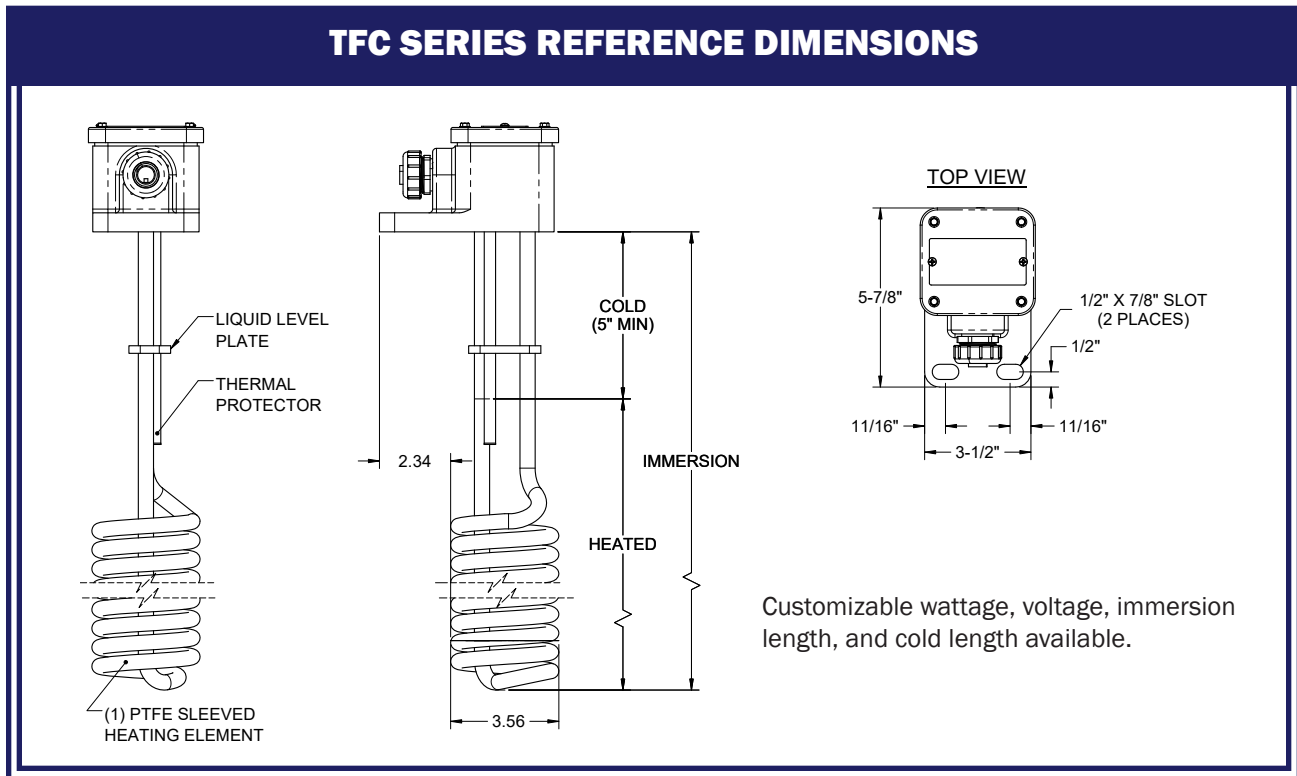

TFC PTFE HEATERS						
PART NUMBER	SPECIFICATIONS					
	Volts	Watts	Immersion Length	Heated Length	Standard Cold Length**	Max Cold Length
TFC-1-05A11-7B-T*	120	500	11"	3.5"	7.5"	40"
TFC-1-05E11-7B-T*	240					
TFC-1-1A11-6-T*	120	1,000	11"	5"	6"	40"
TFC-1-1E11-6-T*	240					
TFC-1-1.5A16-8B-T*	120	1,500	16"	7.5"	8.5"	40"
TFC-1-1.5A16-8B-T*	240					
TFC-1-2E17-8-T*	240	2,000	17"	9"	8"	40"
TFC-1-2M17-8-T*	480					
TFC-1-2.5E17-6-T*	240	2,500	17"	11"	6"	40"
TFC-1-2.5M17-6-T*	480					
TFC-1-3E23-10-T*	240	3,000	23"	13"	10"	33"
TFC-1-3M23-10-T*	480					
TFC-1-3.5E23-8-T*	240	3,500	23"	15"	8"	18"
TFC-1-3.5M23-8-T*	480					
TFC-1-4E23-7-T*	240	4,000	23"	16"	7"	12"
TFC-1-4M23-7-T*	480					

*Specify thermal protection desired, see page (48-49). Please note PTFE should not exceed 212° F.

** Customizable cold lengths available.

TFC SERIES: COILED PTFE HEATERS

PRODUCT FEATURES

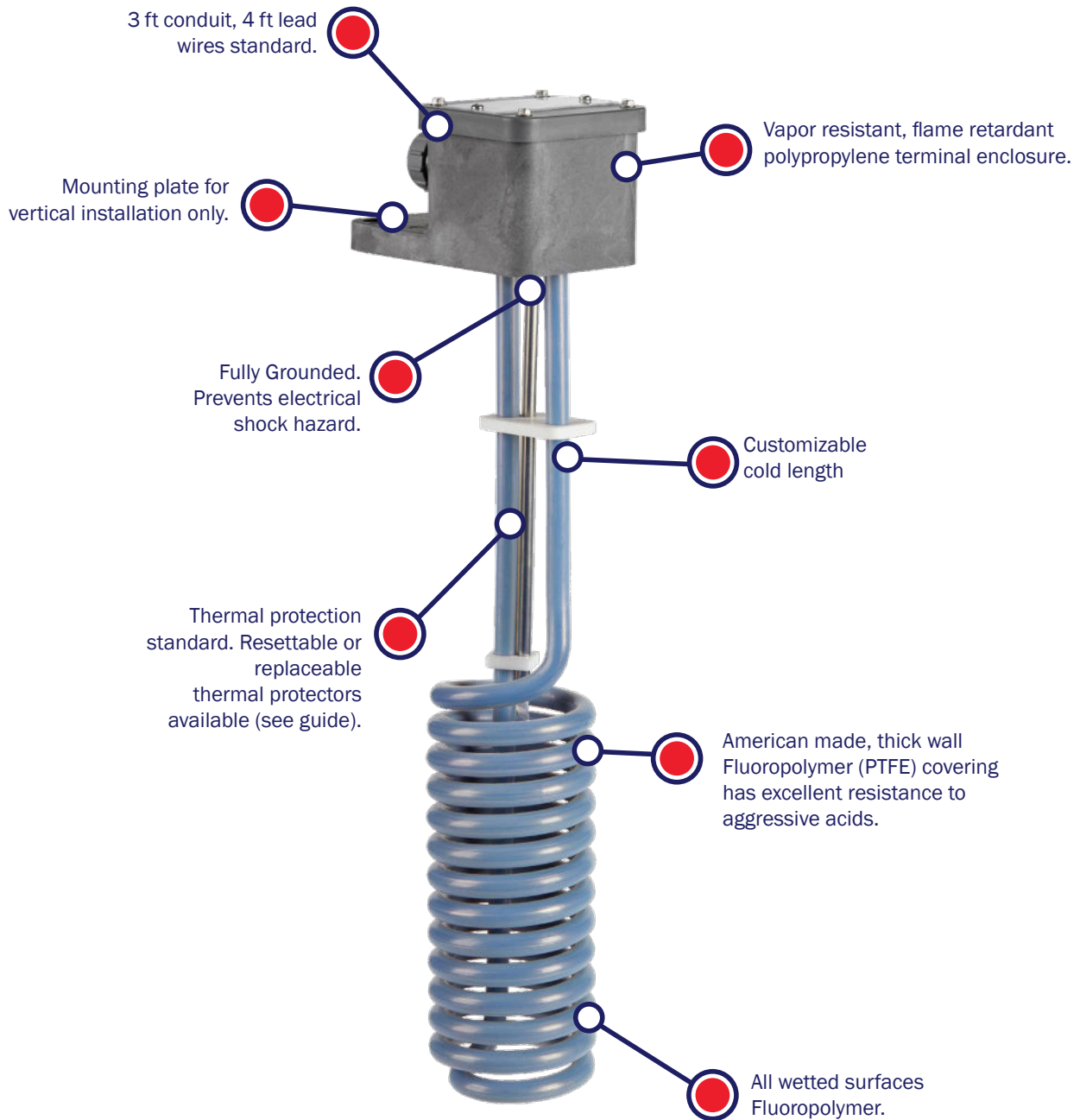

Thermal Protector Guide		
TYPE	MODEL NUMBER	TEMP RANGE
Replaceable Thermal Protectors	T1	Up to 180°F
Resettable Thermal Protectors	T2	Up to 180°F



TFCL SERIES: COILED PTFE HEATERS

An L-shaped variation of the coiled PTFE immersion heater, the **TFCL Series** is designed to heat corrosive chemicals and tight spaces.

Choose the TFCL Series when:

- A PTFE-encapsulated heater is needed for aggressive acids or caustic solutions
- A higher kW or heat up time is required in a small tank

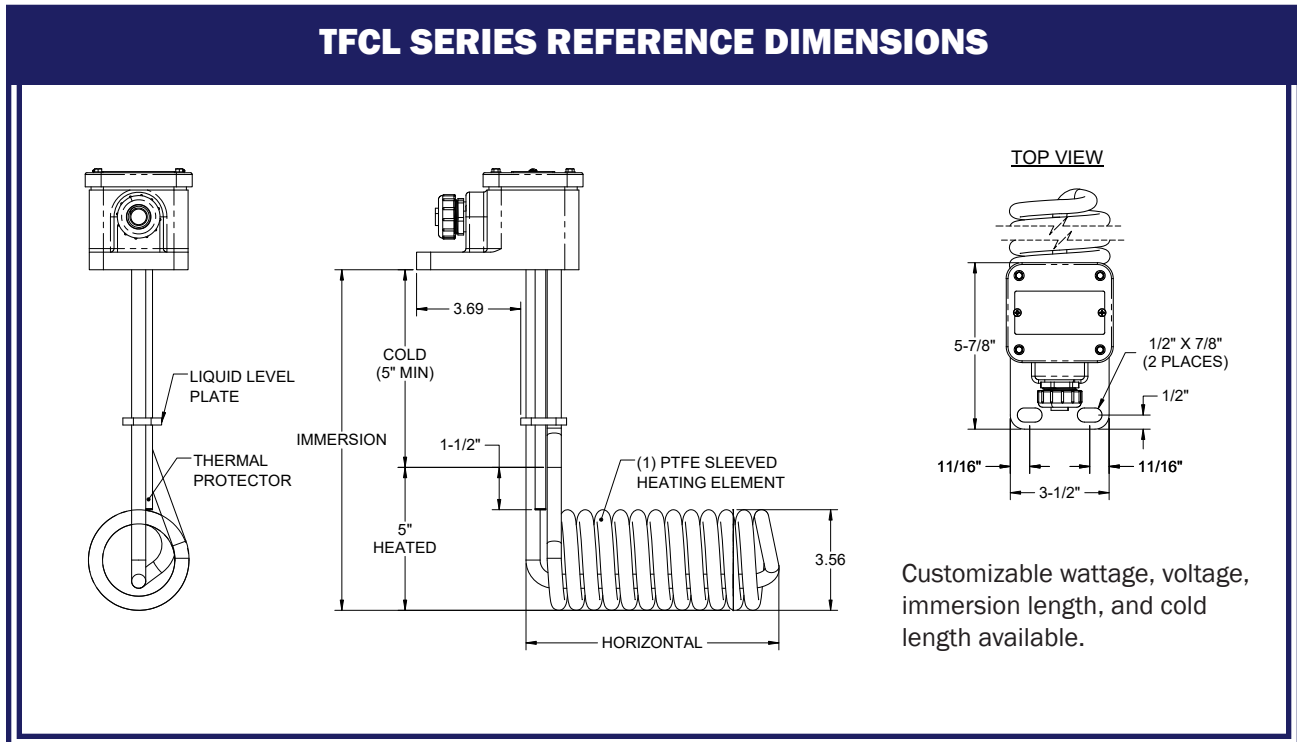

TFCL PTFE HEATERS						
PART NUMBER	SPECIFICATIONS					
	Volts (1-PH)	Watts	Horizontal Length	Vertical Immersion Length	Standard Cold Length**	Max Cold Length
TFCL-1-05A3BR11-T*	120	500	3.5"	11"	6"	40"
TFCL-1-05E3BR11-T*	240					
TFCL-1-1A5R11-T*	120	1,000	5"	11"	6"	40"
TFCL-1-1E5R11-T*	240					
TFCL-1-1.5A7R11-T*	120	1,500	7"	11"	6"	40"
TFCL-1-1.5E7R11-T*	240					
TFCL-1-2E9R17-T*	240	2,000	9"	17"	12"	40"
TFCL-1-2M9R17-T*	480					
TFCL-1-2.5E11R17-T*	240	2,500	11"	17"	12"	40"
TFCL-1-2.5M11R17-T*	480					
TFCL-1-3E12BR23-T*	240	3,000	12.5"	23"	18"	35"
TFCL-1-3M12BR23-T*	480					
TFCL-1-3.5E14BR23-T*	240	3,500	14.5"	23"	18"	20"
TFCL-1-3.5M14BR23-T*	480					

*Specify thermal protection desired, see page (48-49). Please note PTFE should not exceed 212 °F.

** Customizable cold section length.

TFCL SERIES: COILED PTFE HEATERS

PRODUCT FEATURES

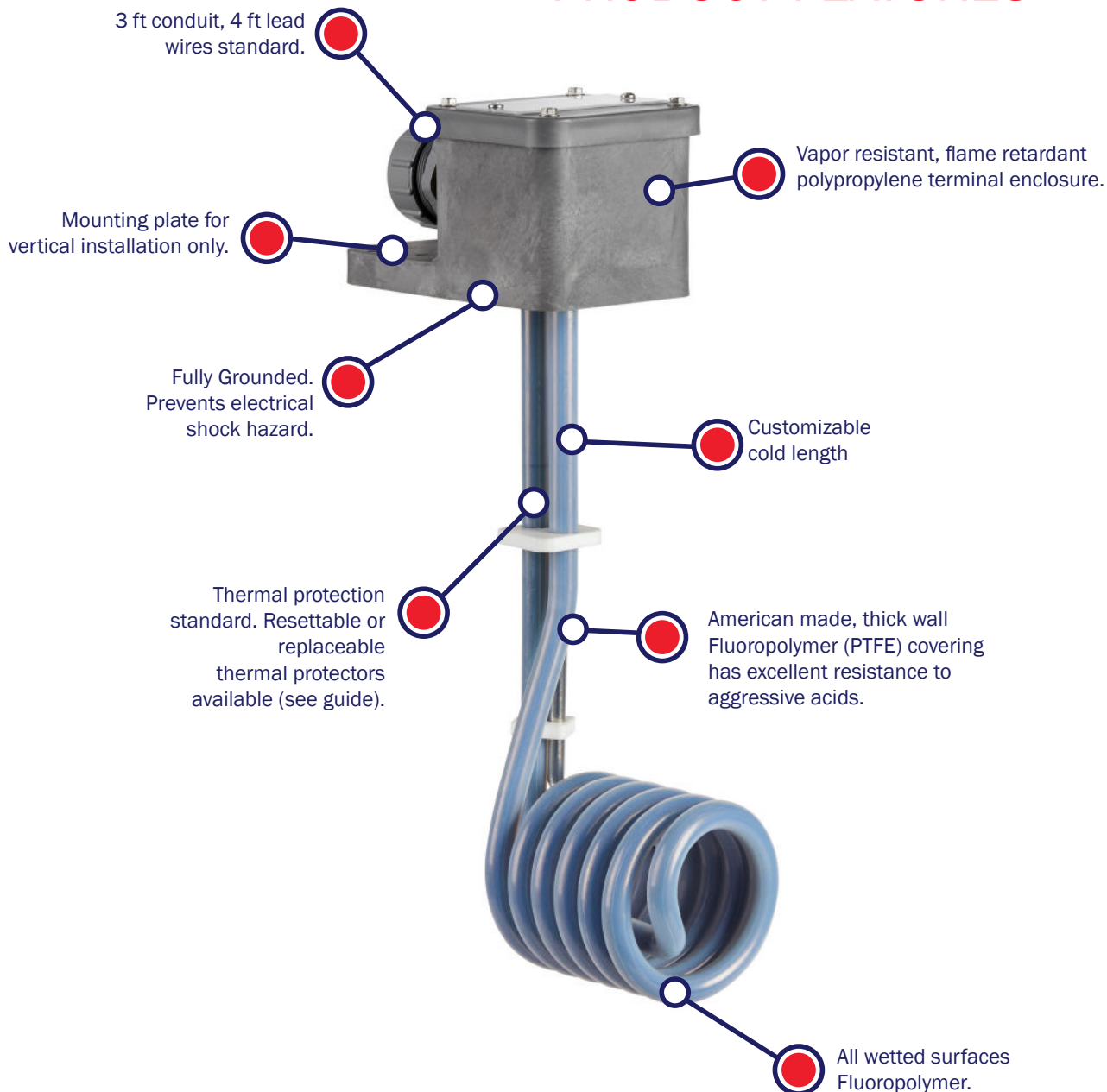

Thermal Protector Guide		
TYPE	MODEL NUMBER	TEMP RANGE
Replaceable Thermal Protectors	T1	Up to 180°F
Resettable Thermal Protectors	T2	Up to 180°F



SW SERIES: OVER-THE-SIDE HEATERS

The **SW Series over-the-side** immersion heaters are designed for open-tanks where they can be installed and removed without draining the tank. Mounted at the tank rim, SW heaters are available in a variety of alloys and watt densities to heat a wide range of industrial process fluids.

Choose the SW Series when:

- The tank is open-topped
- Easy installation and removal are required without draining the tank
- A metal-sheathed heater is suitable for the process chemistry

SW SERIES REFERENCE DIMENSIONS

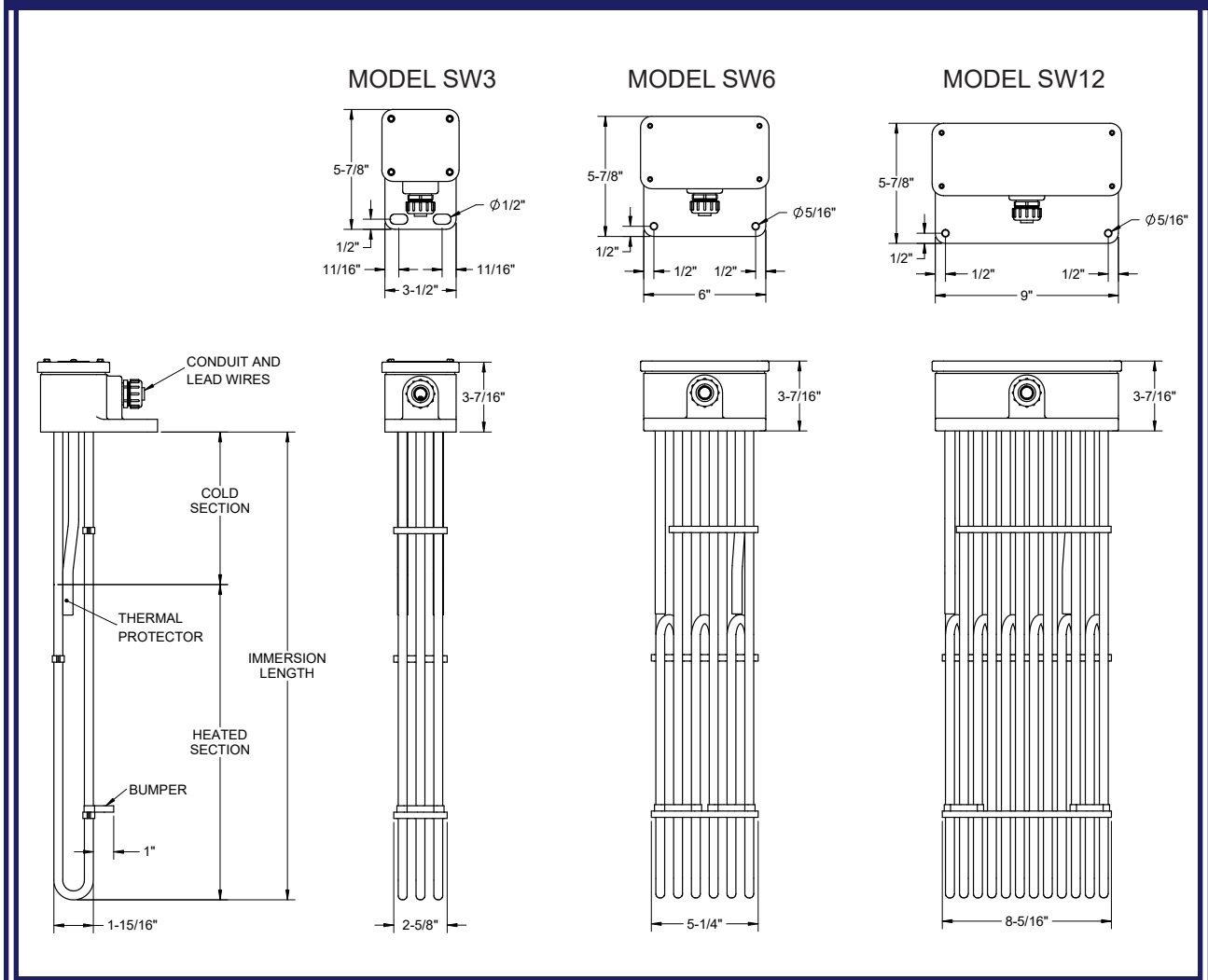

SW SERIES: OVER-THE-SIDE HEATERS

PRODUCT FEATURES

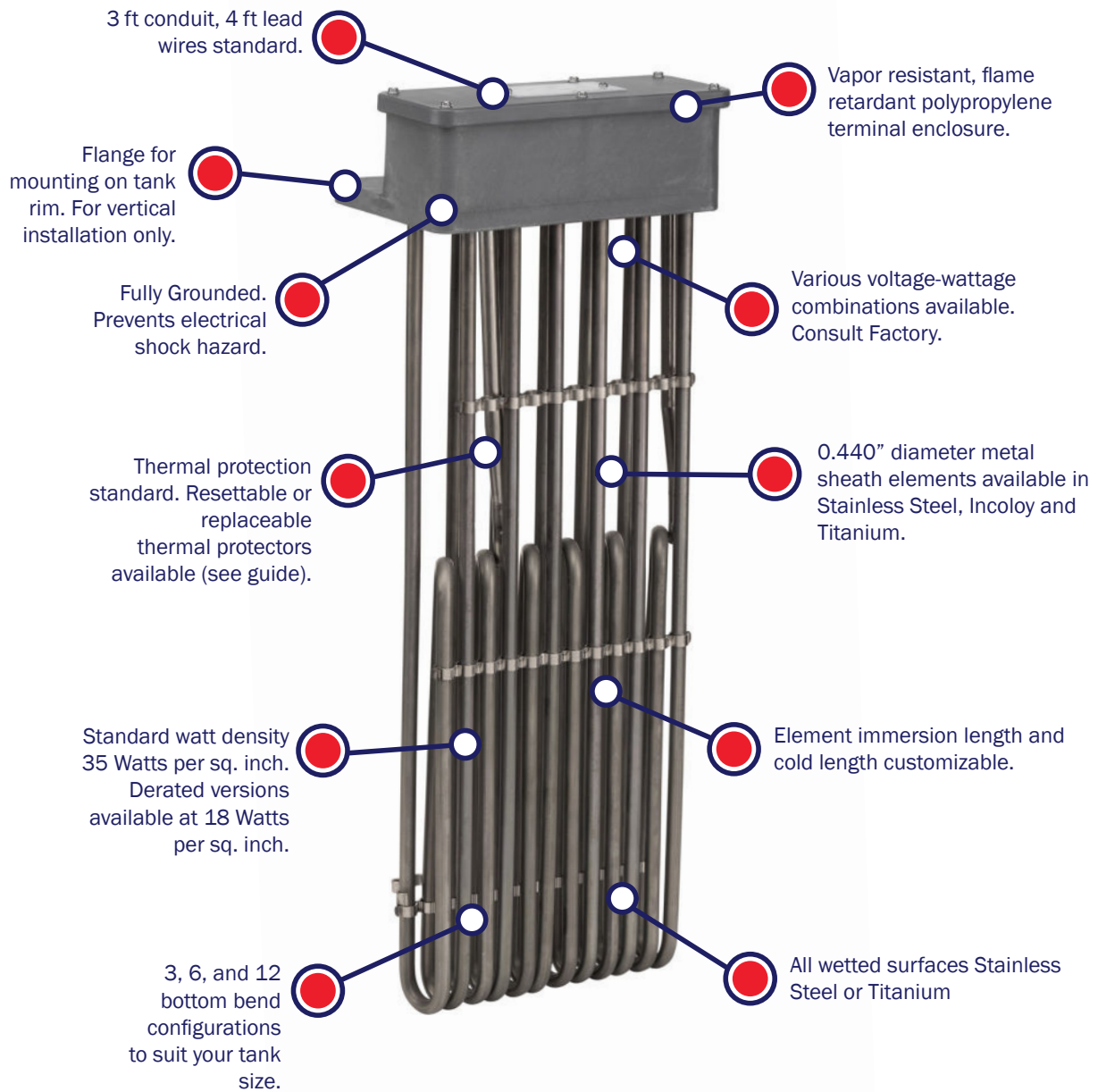

Thermal Protector Guide		
TYPE	MODEL NUMBER	TEMP RANGE
Replaceable Thermal Protectors	T1	Up to 180°F
	T4	Up to 230°F
	T5	Up to 300°F
Resettable Thermal Protectors	T2	Up to 180°F
	T6	Up to 230°F
	T7	Up to 300°F



SW SERIES: OVER-THE-SIDE HEATERS



SW3 METAL OVER THE SIDE HEATERS							
SPECIFICATIONS					304 SS	316 SS	TITANIUM
Volts (1-PH)	Watts	Immersion Length	Heated Length	Cold Length	Part Number	Part Number	Part Number
240	1,000	11	5"	6"	SW3-3F-1EX11-6-T*	SW3-3S-1EX11-6-T*	SW3-3T-1EX11-6-T*
480					SW3-3F-1MX11-6-T*	SW3-3S-1MX11-6-T*	SW3-3T-1MX11-6-T*
240	2,000	17"	10"	7"	SW3-3F-2EX17-7-T*	SW3-3S-2EX17-7-T*	SW3-3T-2EX17-7-T*
480					SW3-3F-2MX17-7-T*	SW3-3S-2MX17-7-T*	SW3-3T-2MX17-7-T*
240	3,000	23"	16"	7"	SW3-3F-3EX23-7-T*	SW3-3S-3EX23-7-T*	SW3-3T-3EX23-7-T*
480					SW3-3F-3MX23-7-T*	SW3-3S-3MX23-7-T*	SW3-3T-3MX23-7-T*
240	4,000	29"	20"	9"	SW3-3F-4EX29-9-T*	SW3-3S-4EX29-9-T*	SW3-3T-4EX29-9-T*
480					SW3-3F-4MX29-9-T*	SW3-3S-4MX29-9-T*	SW3-3T-4MX29-9-T*
240	5,000	35"	25"	10"	SW3-3F-5EX35-10-T*	SW3-3S-5EX35-10-T*	SW3-3T-5EX35-10-T*
480					SW3-3F-5MX35-10-T*	SW3-3S-5MX35-10-T*	SW3-3T-5MX35-10-T*
240	6,000	40"	30"	10"	SW3-3F-6EX40-10-T*	SW3-3S-6EX40-10-T*	SW3-3T-6EX40-10-T*
480					SW3-3F-6MX40-10-T*	SW3-3S-6MX40-10-T*	SW3-3T-6MX40-10-T*
240	8,000	47"	37"	10"	SW3-3F-8EX47-10-T*	SW3-3S-8EX47-10-T*	SW3-3T-8EX47-10-T*
480					SW3-3F-8MX47-10-T*	SW3-3S-8MX47-10-T*	SW3-3T-8MX47-10-T*
240	9,000	54"	44"	10"	SW3-3F-9EX54-10-T*	SW3-3S-9EX54-10-T*	SW3-3T-9EX54-10-T*
480					SW3-3F-9MX54-10-T*	SW3-3S-9MX54-10-T*	SW3-3T-9MX54-10-T*
240	10,000	59"	49"	10"	SW3-3F-10EX59-10-T*	SW3-3S-10EX59-10-T*	SW3-3T-10EX59-10-T*
480					SW3-3F-10MX59-10-T*	SW3-3S-10MX59-10-T*	SW3-3T-10MX59-10-T*
240	12,000	68"	58"	10"	SW3-3F-12EX68-10-T*	SW3-3S-12EX68-10-T*	SW3-3T-12EX68-10-T*
480					SW3-3F-12MX68-10-T*	SW3-3S-12MX68-10-T*	SW3-3T-12MX68-10-T*

*Specify thermal protection desired, see page (48-49).

Above Heaters coded for Single-Phase. Three-Phase option available at no extra charge. Consult factory.

Standard Watt density: 35 Watts per sq. inch.

Note: Additional wattages, watt densities, voltages, immersion and cold lengths available.

SW SERIES: OVER-THE-SIDE HEATERS



SW6 METAL OVER THE SIDE HEATERS							
SPECIFICATIONS					304 SS	316 SS	TITANIUM
Volts (3-PH)	Watts	Immersion Length	Heated Length	Cold Length	Part Number	Part Number	Part Number
240	3,000	11"	5"	6"	SW6-3F-3E11-6-T*	SW6-3S-3E11-6-T*	SW6-3T-3E11-6-T*
480					SW6-3F-3M11-6-T*	SW6-3S-3M11-6-T*	SW6-3T-3M11-6-T*
240	4,500	14"	7"	7"	SW6-3F-4.5E14-7-T*	SW6-3S-4.5E14-7-T*	SW6-3T-4.5E14-7-T*
480					SW6-3F-4.5M14-7-T*	SW6-3S-4.5M14-7-T*	SW6-3T-4.5M14-7-T*
240	6,000	17"	10"	7"	SW6-3F-6E17-7-T*	SW6-3S-6E17-7-T*	SW6-3T-6E17-7-T*
480					SW6-3F-6M17-7-T*	SW6-3S-6M17-7-T*	SW6-3T-6M17-7-T*
240	7,500	20"	13"	7"	SW6-3F-7.5E20-7-T*	SW6-3S-7.5E20-7-T*	SW6-3T-7.5E20-7-T*
480					SW6-3F-7.5M20-7-T*	SW6-3S-7.5M20-7-T*	SW6-3T-7.5M20-7-T*
240	9,000	23"	15"	8"	SW6-3F-9E23-8-T*	SW6-3S-9E23-8-T*	SW6-3T-9E23-8-T*
480					SW6-3F-9M23-8-T*	SW6-3S-9M23-8-T*	SW6-3T-9M23-8-T*
240	12,000	29"	20"	9"	SW6-3F-12E29-9-T*	SW6-3S-12E29-9-T*	SW6-3T-12E29-9-T*
480					SW6-3F-12M29-9-T*	SW6-3S-12M29-9-T*	SW6-3T-12M29-9-T*
240	15,000	35"	25"	10"	SW6-3F-15E35-10-T*	SW6-3S-15E35-10-T*	SW6-3T-15E35-10-T*
480					SW6-3F-15M35-10-T*	SW6-3S-15M35-10-T*	SW6-3T-15M35-10-T*
240	18,000	40"	30"	10"	SW6-3F-18E40-10-T*	SW6-3S-18E40-10-T*	SW6-3T-18E40-10-T*
480					SW6-3F-18M40-10-T*	SW6-3S-18M40-10-T*	SW6-3T-18M40-10-T*
480	21,000	45"	35"	10"	SW6-3F-21M45-10-T*	SW6-3S-21M45-10-T*	SW6-3T-21M45-10-T*
480	24,000	47"	37"	10"	SW6-3F-24M47-10-T*	SW6-3S-24M47-10-T*	SW6-3T-24M47-10-T*
480	27,000	54"	44"	10"	SW6-3F-27M54-10-T*	SW6-3S-27M54-10-T*	SW6-3T-27M54-10-T*
480	30,000	59"	49"	10"	SW6-3F-30M59-10-T*	SW6-3S-30M59-10-T*	SW6-3T-30M59-10-T*
480	36,000	68"	58"	10"	SW6-6F-36M68-10-T*	SW6-6S-36M68-10-T*	SW6-6T-36M68-10-T*

*Specify thermal protection desired, see page (48-49).

Above Heaters coded for Three-Phase. Single-Phase option available at no extra charge. Consult factory.

Standard Watt density: 35 Watts per sq. inch.

Note: Additional wattages, watt densities, voltages, immersion and cold lengths available.

SW SERIES: OVER-THE-SIDE HEATERS



SW12 METAL OVER THE SIDE HEATERS							
SPECIFICATIONS					304 SS	316 SS	TITANIUM
Volts (3-PH)	Watts	Immersion Length	Heated Length	Cold Length	Part Number	Part Number	Part Number
240-3	6,000	13"	6"	7"	SW12-3F-6E13-7-T*	SW12-3S-6E13-7-T*	SW12-3T-6E13-7-T*
480-3					SW12-3F-6M13-7-T*	SW12-3S-6M13-7-T*	SW12-3T-6M13-7-T*
240-3	9,000	16"	8"	8"	SW12-3F-9E16-8-T*	SW12-3S-9E16-8-T*	SW12-3T-9E16-8-T*
480-3					SW12-3F-9M16-8-T*	SW12-3S-9M16-8-T*	SW12-3T-9M16-8-T*
240-3	12,000	19"	11"	8"	SW12-3F-12E19-8-T*	SW12-3S-12E19-8-T*	SW12-3T-12E19-8-T*
480-3					SW12-3F-12M19-8-T*	SW12-3S-12M19-8-T*	SW12-3T-12M19-8-T*
240-3	15,000	23"	14"	9"	SW12-3F-15E23-9-T*	SW12-3S-15E23-9-T*	SW12-3T-15E23-9-T*
480-3					SW12-3F-15M23-9-T*	SW12-3S-15M23-9-T*	SW12-3T-15M23-9-T*
240-3	18,000	25"	16"	9"	SW12-3F-18E25-9-T*	SW12-3S-18E25-9-T*	SW12-3T-18E25-9-T*
480-3					SW12-3F-18M25-9-T*	SW12-3S-18M25-9-T*	SW12-3T-18M25-9-T*
480-3	21,000	27"	18"	9"	SW12-3F-21M27-9-T*	SW12-3S-21M27-9-T*	SW12-3T-21M27-9-T*
480-3	24,000	30"	21"	9"	SW12-6F-24M30-9-T*	SW12-6S-24M30-9-T*	SW12-6T-24M30-9-T*
480-3	27,000	32"	23"	9"	SW12-6F-27M32-9-T*	SW12-6S-27M32-9-T*	SW12-6T-27M32-9-T*
480-3	30,000	35"	26"	9"	SW12-6F-30M35-9-T*	SW12-6S-30M35-9-T*	SW12-6T-30M35-9-T*
480-3	36,000	42"	32"	10"	SW12-6F-36M42-10-T*	SW12-6S-36M42-10-T*	SW12-6T-36M42-10-T*

*Specify thermal protection desired, see page (48-49).

Above Heaters coded for Three-Phase. Single-Phase option available at no extra charge. Consult factory.

Note: Additional wattages, watt densities, voltages, immersion and cold lengths available.

DSW SERIES: OVER-THE-SIDE HEATERS

Derated SW heaters operate at a lower watt density and maintain reduced element surface temperatures, helping minimize chemical attack and sediment build up on the heater sheath. This design approach improves heater service life in challenging process solutions.



Choose the Derated style when:

- Standard Over-the-Side heaters exhibit premature corrosion or shorter service life
- Process solutions (such as Phosphate) are prone to scale, sludge, or sediment build-up on heaters.

DERATED

DSW3 DERATED METAL OVER THE SIDE HEATERS						
SPECIFICATIONS				304 SS	316 SS	TITANIUM
Volts (1-PH)	Watts	Immersion Length	Heated Length	Part Number	Part Number	Part Number
120	500	11	5"	DSW3-3F-05AX11-6-T*	DSW3-3S-05AX11-6-T*	DSW3-3T-05AX11-6-T*
240				DSW3-3F-05EX11-6-T*	DSW3-3S-05EX11-6-T*	DSW3-3T-05EX11-6-T*
240	1,000	17"	10"	DSW3-3F-1EX17-7-T*	DSW3-3S-1EX17-7-T*	DSW3-3T-1EX17-7-T*
480				DSW3-3F-1MX17-7-T*	DSW3-3S-1MX17-7-T*	DSW3-3T-1MX17-7-T*
240	1,500	23"	16"	DSW3-3F-1.5EX23-7-T*	DSW3-3S-1.5EX23-7-T*	DSW3-3T-1.5EX23-7-T*
480				DSW3-3F-1.5MX23-7-T*	DSW3-3S-1.5MX23-7-T*	DSW3-3T-1.5MX23-7-T*
240	2,000	29"	20"	DSW3-3F-2EX29-9-T*	DSW3-3S-2EX29-9-T*	DSW3-3T-2EX29-9-T*
480				DSW3-3F-2MX29-9-T*	DSW3-3S-2MX29-9-T*	DSW3-3T-2MX29-9-T*
240	2,500	35"	25"	DSW3-3F-2.5EX35-10-T*	DSW3-3S-2.5EX35-10-T*	DSW3-3T-2.5EX35-10-T*
480				DSW3-3F-2.5MX35-10-T*	DSW3-3S-2.5MX35-10-T*	DSW3-3T-2.5MX35-10-T*
240	3,000	40"	30"	DSW3-3F-3EX40-10-T*	DSW3-3S-3EX40-10-T*	DSW3-3T-3EX40-10-T*
480				DSW3-3F-3MX40-10-T*	DSW3-3S-3MX40-10-T*	DSW3-3T-3MX40-10-T*
240	4,000	47"	37"	DSW3-3F-4EX47-10-T*	DSW3-3S-4EX47-10-T*	DSW3-3T-4EX47-10-T*
480				DSW3-3F-4MX47-10-T*	DSW3-3S-4MX47-10-T*	DSW3-3T-4MX47-10-T*
240	4,500	54"	44"	DSW3-3F-4.5EX54-10-T*	DSW3-3S-4.5EX54-10-T*	DSW3-3T-4.5EX54-10-T*
480				DSW3-3F-4.5MX54-10-T*	DSW3-3S-4.5MX54-10-T*	DSW3-3T-4.5MX54-10-T*
240	5,000	59"	49"	DSW3-3F-5EX59-10-T*	DSW3-3S-5EX59-10-T*	DSW3-3T-5EX59-10-T*
480				DSW3-3F-5MX59-10-T*	DSW3-3S-5MX59-10-T*	DSW3-3T-5MX59-10-T*
240	6,000	68"	58"	DSW3-3F-6EX68-10-T*	DSW3-3S-6EX68-10-T*	DSW3-3T-6EX68-10-T*
480				DSW3-3F-6MX68-10-T*	DSW3-3S-6MX68-10-T*	DSW3-3T-6MX68-10-T*

*Specify thermal protection desired, see page (48-49).

Derated to 18 Watts per Square Inch Standard.

Heater coded for Single Phase. 3 Phase option available at no extra charge. Remove "X" to make part number 3 Phase.

Note: Additional wattages, voltages, and lengths available.

DSW SERIES: OVER-THE-SIDE HEATERS



DERATED

DSW6 DERATED METAL OVER THE SIDE HEATERS						
SPECIFICATIONS				304 SS	316 SS	TITANIUM
Volts (3-PH)	Watts	Immersion Length	Heated Length	Part Number	Part Number	Part Number
240	1,500	11"	5"	DSW6-3F-1.5E11-6-T*	DSW6-3S-1.5E11-6-T*	DSW6-3T-1.5E11-6-T*
480				DSW6-3F-1.5M11-6-T*	DSW6-3S-1.5M11-6-T*	DSW6-3T-1.5M11-6-T*
240	3,000	17"	10"	DSW6-3F-3E17-7-T*	DSW6-3S-3E17-7-T*	DSW6-3T-3E17-7-T*
480				DSW6-3F-3M17-7-T*	DSW6-3S-3M17-7-T*	DSW6-3T-3M17-7-T*
240	4,500	23"	15"	DSW6-3F-4.5E23-8-T*	DSW6-3S-4.5E23-8-T*	DSW6-3T-4.5E23-8-T*
480				DSW6-3F-4.5M23-8-T*	DSW6-3S-4.5M23-8-T*	DSW6-3T-4.5M23-8-T*
240	6,000	29"	20"	DSW6-3F-6E29-9-T*	DSW6-3S-6E29-9-T*	DSW6-3T-6E29-9-T*
480				DSW6-3F-6M29-9-T*	DSW6-3S-6M29-9-T*	DSW6-3T-6M29-9-T*
240	7,500	35"	25"	DSW6-3F-7.5E35-10-T*	DSW6-3S-7.5E35-10-T*	DSW6-3T-7.5E35-10-T*
480				DSW6-3F-7.5M35-10-T*	DSW6-3S-7.5M35-10-T*	DSW6-3T-7.5M35-10-T*
240	9,000	40"	30"	DSW6-3F-9E40-10-T*	DSW6-3S-9E40-10-T*	DSW6-3T-9E40-10-T*
480				DSW6-3F-9M40-10-T*	DSW6-3S-9M40-10-T*	DSW6-3T-9M40-10-T*
240	12,000	47"	37"	DSW6-3F-12E47-10-T*	DSW6-3S-12E47-10-T*	DSW6-3T-12E47-10-T*
480				DSW6-3F-12M47-10-T*	DSW6-3S-12M47-10-T*	DSW6-3T-12M47-10-T*
240	13,500	54"	44"	DSW6-3F-13.5E54-10-T*	DSW6-3S-13.5E54-10-T*	DSW6-3T-13.5E54-10-T*
480				DSW6-3F-13.5M54-10-T*	DSW6-3S-13.5M54-10-T*	DSW6-3T-13.5M54-10-T*
240	15,000	59"	49"	DSW6-3F-15E59-10-T*	DSW6-3S-15E59-10-T*	DSW6-3T-15E59-10-T*
480				DSW6-3F-15M59-10-T*	DSW6-3S-15M59-10-T*	DSW6-3T-15M59-10-T*
240	18,000	68"	58"	DSW6-6F-18E68-10-T*	DSW6-6S-18E68-10-T*	DSW6-6T-18E68-10-T*
480				DSW6-6F-18M68-10-T*	DSW6-6S-18M68-10-T*	DSW6-6T-18M68-10-T*

*Specify thermal protection desired, see page (48-49).

Derated to 18 Watts per Square Inch Standard.

Heater coded for Three-Phase. Single Phase option available at no extra charge. Consult Factory.

Note: Additional wattages, voltages, and lengths available.

DSW SERIES: OVER-THE-SIDE HEATERS



DERATED

DSW12 SERIES, DERATED METAL OVER THE SIDE HEATERS						
SPECIFICATIONS				304 SS	316 SS	TITANIUM
Volts (3-PH)	Watts	Immersion Length	Heated Length	Part Number	Part Number	Part Number
240	4,500	16"	8"	DSW12-3F-4.5E16-8-T*	DSW12-3S-4.5E16-8-T*	DSW12-3T-4.5E16-8-T*
480				DSW12-3F-4.5M16-8-T*	DSW12-3S-4.5M16-8-T*	DSW12-3T-4.5M16-8-T*
240	6,000	18"	10"	DSW12-3F-6E18-8-T*	DSW12-3S-6E18-8-T*	DSW12-3T-6E18-8-T*
480				DSW12-3F-6M18-8-T*	DSW12-3S-6M18-8-T*	DSW12-3T-6M18-8-T*
240	7,500	21"	13"	DSW12-3F-7.5E21-8-T*	DSW12-3S-7.5E21-8-T*	DSW12-3T-7.5E21-8-T*
480				DSW12-3F-7.5M21-8-T*	DSW12-3S-7.5M21-8-T*	DSW12-3T-7.5M21-8-T*
240	9,000	23"	15"	DSW12-3F-9E23-8-T*	DSW12-3S-9E23-8-T*	DSW12-3T-9E23-8-T*
480				DSW12-3F-9M23-8-T*	DSW12-3S-9M23-8-T*	DSW12-3T-9M23-8-T*
240	12,000	30"	21"	DSW12-3F-12E30-9-T*	DSW12-3S-12E30-9-T*	DSW12-3T-12E30-9-T*
480				DSW12-3F-12M30-9-T*	DSW12-3S-12M30-9-T*	DSW12-3T-12M30-9-T*
240	15,000	35"	26"	DSW12-3F-15E35-9-T*	DSW12-3S-15E35-9-T*	DSW12-3T-15E35-9-T*
480				DSW12-3F-15M35-9-T*	DSW12-3S-15M35-9-T*	DSW12-3T-15M35-9-T*
240	18,000	40"	30"	DSW12-6F-18E40-10-T*	DSW12-6S-18E40-10-T*	DSW12-6T-18E40-10-T*
480				DSW12-6F-18M40-10-T*	DSW12-6S-18M40-10-T*	DSW12-6T-18M40-10-T*
480	20,000	44"	34"	DSW12-6F-20M44-10-T*	DSW12-6S-20M44-10-T*	DSW12-6T-20M44-10-T*
480	22,000	47"	37"	DSW12-6F-22M47-10-T*	DSW12-6S-22M47-10-T*	DSW12-6T-22M47-10-T*
480	26,000	54"	44"	DSW12-6F-26M54-10-T*	DSW12-6S-26M54-10-T*	DSW12-6T-26M54-10-T*
480	29,000	59"	49"	DSW12-6F-29M59-10-T*	DSW12-6S-29M59-10-T*	DSW12-6T-29M59-10-T*

*Specify thermal protection desired, see page (48-49).

Derated to 18 Watts per Square Inch Standard.

Heater coded for Three-Phase. Single Phase option available at no extra charge. Consult factory.

Note: Additional wattages, voltages, and lengths available.

DT SERIES: DEEP TANK HEATERS

Designed for deep tanks, **DT Series** heaters include a long metal riser that allows the elements to be set farther down in the tank.

Choose the DT Series when:

- Heating a deep tank
- Liquid level fluctuates, requiring a long cold section.

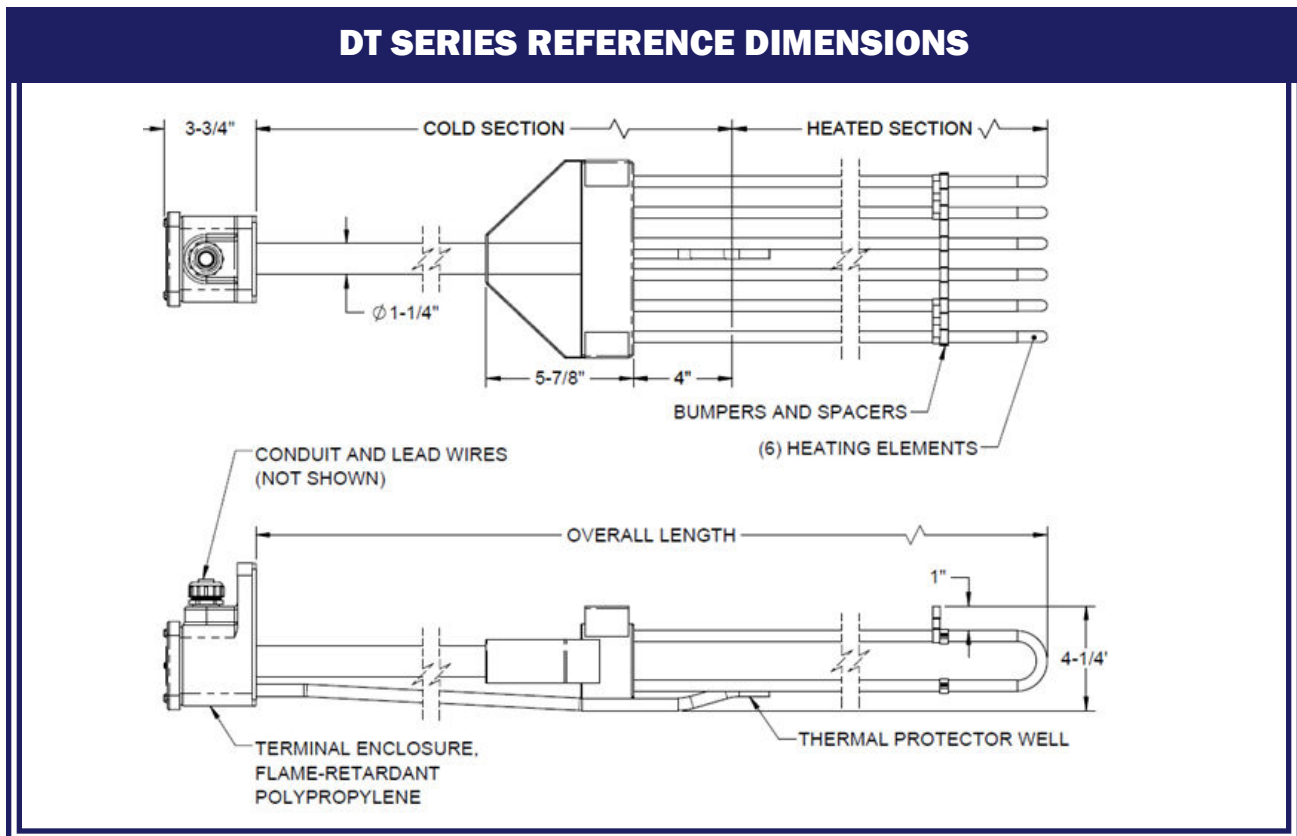

DT SERIES TANK HEATER						
SPECIFICATIONS				304 Stainless Steel	316 Stainless Steel	Titanium
Volts	Watts	Total Immersion Length	Cold Length**	Part Number	Part Number	Part Number
240	18,000	36"	12" Min	SW6-6F-18E36-*T*-DT	SW6-6S-18E36-*T*-DT	SW6-6T-18E36-*T*-DT
480				SW6-6F-18M36-*T*-DT	SW6-6S-18M36-*T*-DT	SW6-6T-18M36-*T*-DT
480	24,000	44"		SW6-6F-24M44-*T*-DT	SW6-6S-24M44-*T*-DT	SW6-6T-24M44-*T*-DT
480	27,000	50"		SW6-6F-27M50-*T*-DT	SW6-6S-27M50-*T*-DT	SW6-6T-27M50-*T*-DT
480	30,000	55"		SW6-6F-30M55-*T*-DT	SW6-6S-30M55-*T*-DT	SW6-6T-30M55-*T*-DT
480	36,000	64"		SW6-6F-36M64-*T*-DT	SW6-6S-36M64-*T*-DT	SW6-6T-36M64-*T*-DT

*Specify thermal protection desired, see page (48-49).

** Coded for minimum cold length, consult factory for customizable, longer cold lengths for deep tank applications.

Note: Additional wattages, voltages, and lengths available.

DT SERIES: DEEP TANK HEATERS

PRODUCT FEATURES

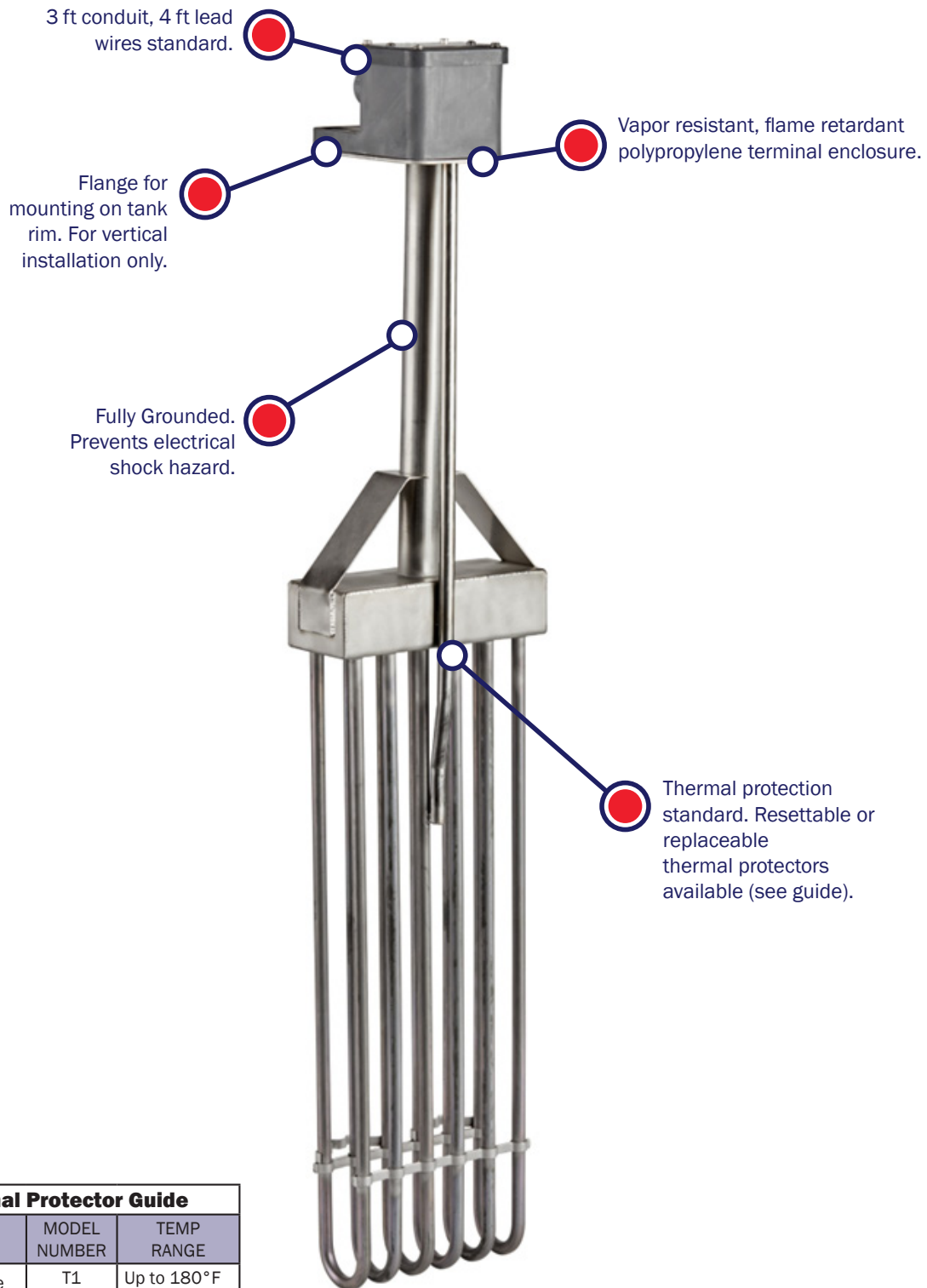

Thermal Protector Guide		
TYPE	MODEL NUMBER	TEMP RANGE
Replaceable Thermal Protectors	T1	Up to 180°F
	T4	Up to 230°F
	T5	Up to 300°F
Resettable Thermal Protectors	T2	Up to 180°F
	T6	Up to 230°F
	T7	Up to 300°F



L SERIES: IMMERSION HEATERS

The **L Series** heaters are designed to rest at the bottom of an open-topped tank, allowing natural convection to distribute heat efficiently as it rises through the process solution. This configuration is well suited for shallow tanks, or applications with fluctuating liquid levels.

Choose the L Series when:

- Uniform heat distribution is needed, particularly in shallow tanks.
- Liquid levels fluctuate and L-shape design is required to keep the elements submerged
- Tank geometry or obstructions limit the use of over-the-side heaters

L SERIES REFERENCE DIMENSIONS

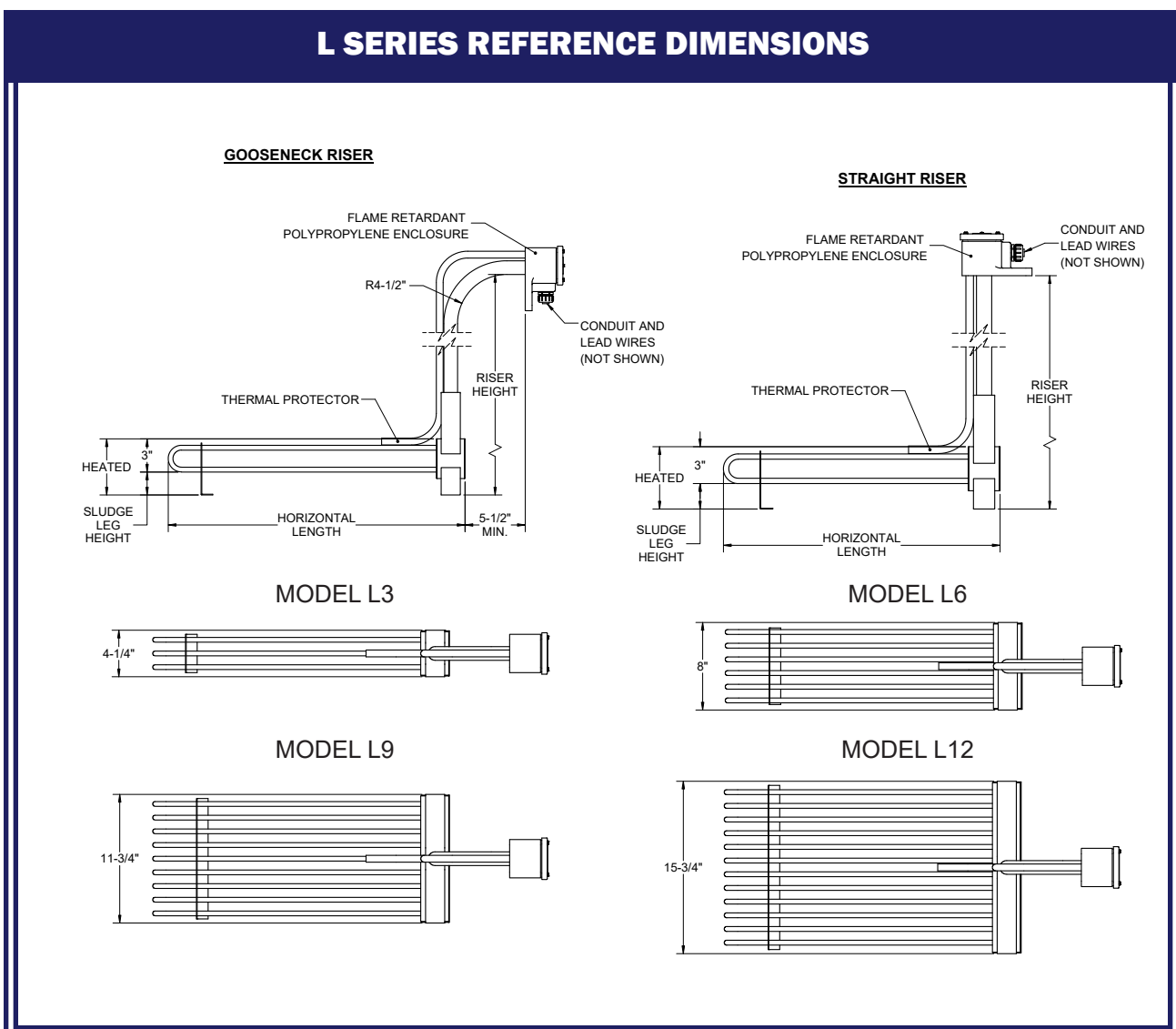

L SERIES: IMMERSION HEATERS

PRODUCT FEATURES

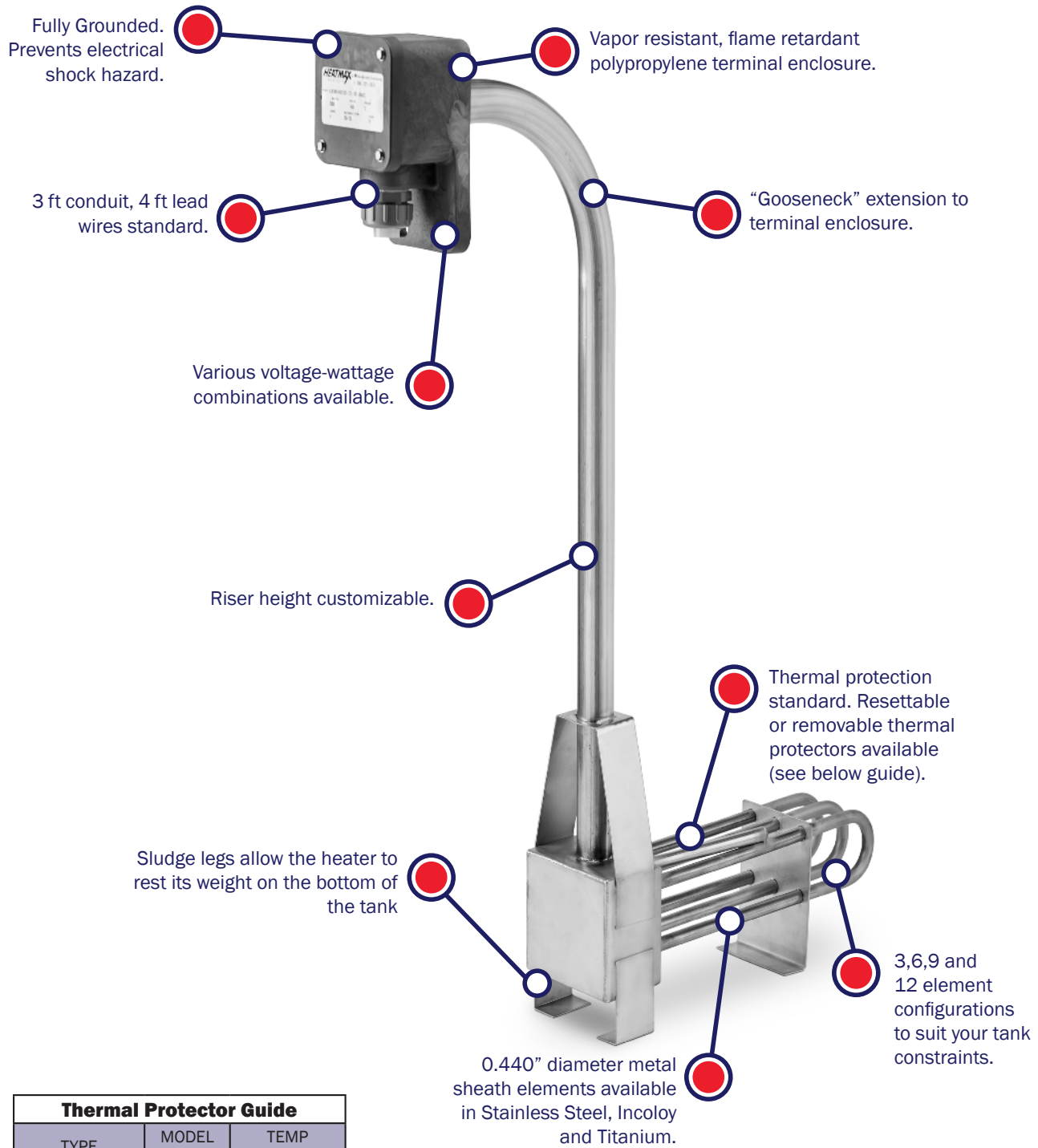

Thermal Protector Guide		
TYPE	MODEL NUMBER	TEMP RANGE
Replaceable Thermal Protectors	T1	Up to 180°F
	T4	Up to 230°F
	T5	Up to 300°F
Resettable Thermal Protectors	T2	Up to 180°F
	T6	Up to 230°F
	T7	Up to 300°F



L SERIES: IMMERSION HEATERS



L3 METAL L-SHAPE HEATERS							
SPECIFICATIONS				304 SS	316 SS	TITANIUM	
Volts (1-PH)	Watts	Bottom Length	Vertical Height	Part Number	Part Number	Part Number	
120	1,000	13"	37"	L3F1AX13R37S2-T*	L3S1AX13R37S2-T*	L3T1AX13R37S2-T*	
240				L3F1EX13R37S2-T*	L3S1EX13R37S2-T*	L3T1EX13R37S2-T*	
120	2,000	17"		L3F2AX17R37S2-T*	L3S2AX17R37S2-T*	L3T2AX17R37S2-T*	
240				L3F2EX17R37S2-T*	L3S2EX17R37S2-T*	L3T2EX17R37S2-T*	
240	3,000	22"		L3F3EX22R37S2-T*	L3S3EX22R37S2-T*	L3T3EX22R37S2-T*	
480				L3F3MX22R37S2-T*	L3S3MX22R37S2-T*	L3T3MX22R37S2-T*	
240	4,000	26"		L3F4EX26R37S2-T*	L3S4EX26R37S2-T*	L3T4EX26R37S2-T*	
480				L3F4MX26R37S2-T*	L3S4MX26R37S2-T*	L3T4MX26R37S2-T*	
240	5,000	31"		L3F5EX31R37S2-T*	L3S5EX31R37S2-T*	L3T5EX31R37S2-T*	
480				L3F5MX31R37S2-T*	L3S5MX31R37S2-T*	L3T5MX31R37S2-T*	
240	6,000	36"		50"	L3F6EX36R50S2-T*	L3S6EX36R50S2-T*	L3T6EX36R50S2-T*
480					L3F6MX36R50S2-T*	L3S6MX36R50S2-T*	L3T6MX36R50S2-T*
240	8,000	44"	L3F8EX44R50S2-T*		L3S8EX44R50S2-T*	L3T8EX44R50S2-T*	
480			L3F8MX44R50S2-T*		L3S8MX44R50S2-T*	L3T8MX44R50S2-T*	
240	9,000	50"	L3F9EX50R50S2-T*		L3S9EX50R50S2-T*	L3T9EX50R50S2-T*	
480			L3F9MX50R50S2-T*		L3S9MX50R50S2-T*	L3T9MX50R50S2-T*	
240	10,000	55"	L3F10EX55R50S2-T*		L3S10EX55R50S2-T*	L3T10EX55R50S2-T*	
480			L3F10MX55R50S2-T*		L3S10MX55R50S2-T*	L3T10MX55R50S2-T*	
480	12,000	64"	L3F12MX64R50S2-T*		L3S12MX64R50S2-T*	L3T12MX64R50S2-T*	
480	15,000	65"	L3F15MX65R50S2-T*		L3S15MX65R50S2-T*	L3T15MX65R50S2-T*	
480	18,000	67"	L3F18MX67R50S2-T*		L3S18MX67R50S2-T*	L3T18MX67R50S2-T*	

*Specify thermal protection desired, see page (48-49).
 Heater coded for Single Phase. 3 Phase option available at no extra charge. Remove "X" to make part number 3 Phase.

Note: Additional wattages, voltages, and lengths available.

L SERIES: IMMERSION HEATERS



L6 METAL L-SHAPE HEATERS						
SPECIFICATIONS				304 SS	316 SS	TITANIUM
Volts (3-PH)	Watts	Bottom Length	Vertical Height	Part Number	Part Number	Part Number
240	3,000	13"	37"	L6F3E13R37S2-T*	L6S3E13R37S2-T*	L6T3E13R37S2-T*
480				L6F3M13R37S2-T*	L6S3M13R37S2-T*	L6T3M13R37S2-T*
240	6,000	17"		L6F6E17R37S2-T*	L6S6E17R37S2-T*	L6T6E17R37S2-T*
480				L6F6M17R37S2-T*	L6S6M17R37S2-T*	L6T6M17R37S2-T*
240	9,000	22"		L6F9E22R37S2-T*	L6S9E22R37S2-T*	L6T9E22R37S2-T*
480				L6F9M22R37S2-T*	L6S9M22R37S2-T*	L6T9M22R37S2-T*
240	12,000	26"		L6F12E26R37S2-T*	L6S12E26R37S2-T*	L6T12E26R37S2-T*
480				L6F12M26R37S2-T*	L6S12M26R37S2-T*	L6T12M26R37S2-T*
240	15,000	31"		L6F15E31R37S2-T*	L6S15E31R37S2-T*	L6T15E31R37S2-T*
480				L6F15M31R37S2-T*	L6S15M31R37S2-T*	L6T15M31R37S2-T*
240	18,000	36"		L6F18E36R50S2-T*	L6S18E36R50S2-T*	L6T18E36R50S2-T*
480				L6F18M36R50S2-T*	L6S18M36R50S2-T*	L6T18M36R50S2-T*
480	21,000	40"	L6F21M40R50S2-T*	L6S21M40R50S2-T*	L6T21M40R50S2-T*	
480	24,000	44"	L6F24M44R50S2-T*	L6S24M44R50S2-T*	L6T24M44R50S2-T*	
480	27,000	50"	L6F27M50R50S2-T*	L6S27M50R50S2-T*	L6T27M50R50S2-T*	
480	30,000	55"	L6F30M55R50S2-T*	L6S30M55R50S2-T*	L6T30M55R50S2-T*	
480	36,000	64"	L6F36M64R50S2-T*	L6S36M64R50S2-T*	L6T36M64R50S2-T*	

*Specify thermal protection desired, see page (48-49).
 Heater coded for 3 Phase. Single Phase option available at no extra charge.

Note: Additional wattages, voltages, and lengths available.

L SERIES: IMMERSION HEATERS



L9 METAL L-SHAPE HEATERS						
SPECIFICATIONS				304 SS	316 SS	TITANIUM
Volts (3-PH)	Watts	Bottom Length	Vertical Height	Part Number	Part Number	Part Number
240	6,000	12"	50"	L9F6E12R50S2-T*	L9S6E12R50S2-T*	L9T6E12R50S2-T*
480				L9F6M12R50S2-T*	L9S6M12R50S2-T*	L9T6M12R50S2-T*
240	9,000	15"		L9F9E15R50S2-T*	L9S9E15R50S2-T*	L9T9E15R50S2-T*
480				L9F9M15R50S2-T*	L9S9M15R50S2-T*	L9T9M15R50S2-T*
240	12,000	18"		L9F12E18R50S2-T*	L9S12E18R50S2-T*	L9T12E18R50S2-T*
480				L9F12M18R50S2-T*	L9S12M18R50S2-T*	L9T12M18R50S2-T*
240	15,000	22"		L9F15E22R50S2-T*	L9S15E22R50S2-T*	L9T15E22R50S2-T*
480				L9F15M22R50S2-T*	L9S15M22R50S2-T*	L9T15M22R50S2-T*
240	18,000	25"		L9F18E25R50S2-T*	L9S18E25R50S2-T*	L9T18E25R50S2-T*
480				L9F18M25R50S2-T*	L9S18M25R50S2-T*	L9T18M25R50S2-T*
480	21,000	29"		L9F21M29R50S2-T*	L9S21M29R50S2-T*	L9T21M29R50S2-T*
480	24,000	32"		L9F24M32R50S2-T*	L9S24M32R50S2-T*	L9T24M32R50S2-T*
480	27,000	36"		L9F27M36R50S2-T*	L9S27M36R50S2-T*	L9T27M36R50S2-T*
480	30,000	39"		L9F30M39R50S2-T*	L9S30M39R50S2-T*	L9T30M39R50S2-T*
480	36,000	55"		L9F36M55R50S2-T*	L9S36M55R50S2-T*	L9T36M55R50S2-T*

*Specify thermal protection desired, see page (48-49).
Heater coded for 3 Phase. 3 Phase option available at no extra charge.

Note: Additional wattages, voltages, and lengths available.

L SERIES: IMMERSION HEATERS



L12 METAL L-SHAPE HEATERS						
SPECIFICATIONS				304 SS	316 SS	TITANIUM
Volts (3-PH)	Watts	Bottom Length	Vertical Height	Part Number	Part Number	Part Number
240	9,000	13"	50"	L12F9E13R50S2-T*	L12S9E13R50S2-T*	L12T9E13R50S2-T*
480				L12F9M13R50S2-T*	L12S9M13R50S2-T*	L12T9M13R50S2-T*
240	12,000	15"		L12F12E15R50S2-T*	L12S12E15R50S2-T*	L12T12E15R50S2-T*
480				L12F12M15R50S2-T*	L12S12M15R50S2-T*	L12T12M15R50S2-T*
240	15,000	18"		L12F15E18R50S2-T*	L12S15E18R50S2-T*	L12T15E18R50S2-T*
480				L12F15M18R50S2-T*	L12S15M18R50S2-T*	L12T15M18R50S2-T*
240	18,000	20"		L12F18E20R50S2-T*	L12S18E20R50S2-T*	L12T18E20R50S2-T*
480				L12F18M20R50S2-T*	L12S18M20R50S2-T*	L12T18M20R50S2-T*
480	21,000	23"		L12F21M23R50S2-T*	L12S21M23R50S2-T*	L12T21M23R50S2-T*
480	24,000	26"		L12F24M26R50S2-T*	L12S24M26R50S2-T*	L12T24M26R50S2-T*
480	27,000	28"		L12F27M28R50S2-T*	L12S27M28R50S2-T*	L12T27M28R50S2-T*
480	30,000	31"		L12F30M31R50S2-T*	L12S30M31R50S2-T*	L12T30M31R50S2-T*
480	36,000	40"		L12F36M40R50S2-T*	L12S36M40R50S2-T*	L12T36M40R50S2-T*

*Specify thermal protection desired, see page (48-49).
 Heater coded for 3 Phase. Single Phase option available at no extra charge.

Note: Additional wattages, voltages, and lengths available.

DL SERIES: IMMERSION HEATERS

Derated L-shaped heaters operate at a lower watt density and maintain reduced element surface temperatures, helping to minimize chemical attack and sediment build up on the heater sheath. This design approach improves heater service life in challenging process solutions.



DERATED

Choose the Derated style when:

- Standard L-shaped heaters exhibit premature corrosion or shorter service life
- Process solutions (such as Phosphate) are prone to scale, sludge, or sediment build-up on heaters.

DL3 DERATED METAL L-SHAPE HEATERS						
SPECIFICATIONS				304 SS	316 SS	TITANIUM
Volts (1-PH)	Watts	Bottom Length	Vertical Height	Part Number	Part Number	Part Number
120	500	13"	37"	DL3F05AX13R37S2-T*	DL3S05AX13R37S2-T*	DL3T05AX13R37S2-T*
240				DL3F05EX13R37S2-T*	DL3S05EX13R37S2-T*	DL3T05EX13R37S2-T*
120	1,000	17"		DL3F1AX17R37S2-T*	DL3S1AX17R37S2-T*	DL3T1AX17R37S2-T*
240				DL3F1EX17R37S2-T*	DL3S1EX17R37S2-T*	DL3T1EX17R37S2-T*
240	1,500	22"		DL3F1.5EX22R37S2-T*	DL3S1.5EX22R37S2-T*	DL3T1.5EX22R37S2-T*
480				DL3F1.5MX22R37S2-T*	DL3S1.5MX22R37S2-T*	DL3T1.5MX22R37S2-T*
240	2,000	26"		DL3F2EX26R37S2-T*	DL3S2EX26R37S2-T*	DL3T2EX26R37S2-T*
480				DL3F2MX26R37S2-T*	DL3S2MX26R37S2-T*	DL3T2MX26R37S2-T*
240	2,500	31"		DL3F2.5EX31R37S2-T*	DL3S2.5EX31R37S2-T*	DL3T2.5EX31R37S2-T*
480				DL3F2.5MX31R37S2-T*	DL3S2.5MX31R37S2-T*	DL3T2.5MX31R37S2-T*
240	3,000	36"		DL3F3EX36R50S2-T*	DL3S3EX36R50S2-T*	DL3T3EX36R50S2-T*
480				DL3F3MX36R50S2-T*	DL3S3MX36R50S2-T*	DL3T3MX36R50S2-T*
240	4,000	44"	DL3F4EX44R50S2-T*	DL3S4EX44R50S2-T*	DL3T4EX44R50S2-T*	
480			DL3F4MX44R50S2-T*	DL3S4MX44R50S2-T*	DL3T4MX44R50S2-T*	
240	4,500	50"	DL3F4.5EX50R50S2-T*	DL3S4.5EX50R50S2-T*	DL3T4.5EX50R50S2-T*	
480			DL3F4.5MX50R50S2-T*	DL3S4.5MX50R50S2-T*	DL3T4.5MX50R50S2-T*	
240	5,000	55"	DL3F5EX55R50S2-T*	DL3S5EX55R50S2-T*	DL3T5EX55R50S2-T*	
480			DL3F5MX55R50S2-T*	DL3S5MX55R50S2-T*	DL3T5MX55R50S2-T*	
240	6,000	64"	DL3F6EX64R50S2-T*	DL3S6EX64R50S2-T*	DL3T6EX64R50S2-T*	
480			DL3F6MX64R50S2-T*	DL3S6MX64R50S2-T*	DL3T6MX64R50S2-T*	

*Specify thermal protection desired, see page (48-49)
 Derated to 18 Watts per Square Inch Standard.
 Heater coded for Single Phase. 3 Phase option available at no extra charge.

Note: Additional wattages, voltages, and lengths available.

DL SERIES: IMMERSION HEATERS



DERATED

DL6 DERATED METAL L-SHAPE HEATERS						
SPECIFICATIONS				304 SS	316 SS	TITANIUM
Volts (3-PH)	Watts	Bottom Length	Vertical Height	Part Number	Part Number	Part Number
240	1,500	13"	37"	DL6F1.5E13R37S2-T*	DL6S1.5E13R37S2-T*	DL6T1.5E13R37S2-T*
480				DL6F1.5M13R37S2-T*	DL6S1.5M13R37S2-T*	DL6T1.5M13R37S2-T*
240	3,000	17"		DL6F3E17R37S2-T*	DL6S3E17R37S2-T*	DL6T3E17R37S2-T*
480				DL6F3M17R37S2-T*	DL6S3M17R37S2-T*	DL6T3M17R37S2-T*
240	4,500	22"		DL6F4.5E22R37S2-T*	DL6S4.5E22R37S2-T*	DL6T4.5E22R37S2-T*
480				DL6F4.5M22R37S2-T*	DL6S4.5M22R37S2-T*	DL6T4.5M22R37S2-T*
240	6,000	26"		DL6F6E26R37S2-T*	DL6S6E26R37S2-T*	DL6T6E26R37S2-T*
480				DL6F6M26R37S2-T*	DL6S6M26R37S2-T*	DL6T6M26R37S2-T*
240	7,500	31"		DL6F7.5E31R37S2-T*	DL6S7.5E31R37S2-T*	DL6T7.5E31R37S2-T*
480				DL6F7.5M31R37S2-T*	DL6S7.5M31R37S2-T*	DL6T7.5M31R37S2-T*
240	9,000	36"		DL6F9E36R50S2-T*	DL6S9E36R50S2-T*	DL6T9E36R50S2-T*
480				DL6F9M36R50S2-T*	DL6S9M36R50S2-T*	DL6T9M36R50S2-T*
240	10,500	40"	DL6F10.5E40R50S2-T*	DL6S10.5E40R50S2-T*	DL6T10.5E40R50S2-T*	
480			DL6F10.5M40R50S2-T*	DL6S10.5M40R50S2-T*	DL6T10.5M40R50S2-T*	
240	12,000	44"	DL6F12E44R50S2-T*	DL6S12E44R50S2-T*	DL6T12E44R50S2-T*	
480			DL6F12M44R50S2-T*	DL6S12M44R50S2-T*	DL6T12M44R50S2-T*	
240	13,500	50"	DL6F13.5E50R50S2-T*	DL6S13.5E50R50S2-T*	DL6T13.5E50R50S2-T*	
480			DL6F13.5M50R50S2-T*	DL6S13.5M50R50S2-T*	DL6T13.5M50R50S2-T*	
240	15,000	55"	DL6F15E55R50S2-T*	DL6S15E55R50S2-T*	DL6T15E55R50S2-T*	
480			DL6F15M55R50S2-T*	DL6S15M55R50S2-T*	DL6T15M55R50S2-T*	
240	18,000	64"	DL6F18E64R50S2-T*	DL6S18E64R50S2-T*	DL6T18E64R50S2-T*	
480			DL6F18M64R50S2-T*	DL6S18M64R50S2-T*	DL6T18M64R50S2-T*	

*Specify thermal protection desired, see page (48-49).
 Derated to 18 Watts per Square Inch Standard.
 Heater coded for 3-Phase. Single Phase option available at no extra charge.

Note: Additional wattages, voltages, and lengths available.

DL SERIES: IMMERSION HEATERS



DERATED

DL9 DERATED METAL L-SHAPE HEATERS						
SPECIFICATIONS				304 SS	316 SS	TITANIUM
Volts (3-PH)	Watts	Bottom Length	Vertical Height	Part Number	Part Number	Part Number
240	3,000	11"	37"	DL9F3E11R37S2-T*	DL9S3E11R37S2-T*	DL9T3E11R37S2-T*
480				DL9F3M11R37S2-T*	DL9S3M11R37S2-T*	DL9T3M11R37S2-T*
240	4,500	15"		DL9F4.5E15R37S2-T*	DL9S4.5E15R37S2-T*	DL9T4.5E15R37S2-T*
480				DL9F4.5M15R37S2-T*	DL9S4.5M15R37S2-T*	DL9T4.5M15R37S2-T*
240	6,000	18"		DL9F6E18R37S2-T*	DL9S6E18R37S2-T*	DL9T6E18R37S2-T*
480				DL9F6M18R37S2-T*	DL9S6M18R37S2-T*	DL9T6M18R37S2-T*
240	7,500	22"	DL9F7.5E22R37S2-T*	DL9S7.5E22R37S2-T*	DL9T7.5E22R37S2-T*	
480			DL9F7.5M22R37S2-T*	DL9S7.5M22R37S2-T*	DL9T7.5M22R37S2-T*	
240	9,000	27"	50"	DL9F8.5E27R50S2-T*	DL9S8.5E27R50S2-T*	DL9T8.5E27R50S2-T*
480				DL9F8.5M27R50S2-T*	DL9S8.5M27R50S2-T*	DL9T8.5M27R50S2-T*
240	12,000	36"		DL9F12E36R50S2-T*	DL9S12E36R50S2-T*	DL9T12E36R50S2-T*
480				DL9F12M36R50S2-T*	DL9S12M36R50S2-T*	DL9T12M36R50S2-T*
240	13,500	40"		DL9F13.5E40R50S2-T*	DL9S13.5E40R50S2-T*	DL9T13.5E40R50S2-T*
480				DL9F13.5M40R50S2-T*	DL9S13.5M40R50S2-T*	DL9T13.5M40R50S2-T*
240	15,000	44"		DL9F15E44R50S2-T*	DL9S15E44R50S2-T*	DL9T15E44R50S2-T*
480				DL9F15M44R50S2-T*	DL9S15M44R50S2-T*	DL9T15M44R50S2-T*
240	18,000	55"		DL9F18E55R50S2-T*	DL9S18E55R50S2-T*	DL9T18E55R50S2-T*
480				DL9F18M55R50S2-T*	DL9S18M55R50S2-T*	DL9T18M55R50S2-T*

*Specify thermal protection desired, see page (48-49).

Derated to 18 Watts per Square Inch Standard.

Heater coded for 3-Phase. Single Phase option available at no extra charge.

Note: Additional wattages, voltages, and lengths available.

DL SERIES: IMMERSION HEATERS



DERATED

DL12 DERATED METAL L-SHAPE HEATERS						
SPECIFICATIONS				304 SS	316 SS	TITANIUM
Volts (3-PH)	Watts	Bottom Length	Vertical Height	Part Number	Part Number	Part Number
240	4,500	12"	50"	DL12F4.5E12R50S2-T*	DL12S4.5E12R50S2-T*	DL12T4.5E12R50S2-T*
480				DL12F4.5M12R50S2-T*	DL12S4.5M12R50S2-T*	DL12T4.5M12R50S2-T*
240	6,000	15"		DL12F6E15R50S2-T*	DL12S6E15R50S2-T*	DL12T6E15R50S2-T*
480				DL12F6M15R50S2-T*	DL12S6M15R50S2-T*	DL12T6M15R50S2-T*
240	7,500	17"		DL12F7.5E17R50S2-T*	DL12S7.5E17R50S2-T*	DL12T7.5E17R50S2-T*
480				DL12F7.5M17R50S2-T*	DL12S7.5M17R50S2-T*	DL12T7.5M17R50S2-T*
240	9,000	20"		DL12F9E20R50S2-T*	DL12S9E20R50S2-T*	DL12T9E20R50S2-T*
480				DL12F9M20R50S2-T*	DL12S9M20R50S2-T*	DL12T9M20R50S2-T*
240	12,000	25"		DL12F12E25R50S2-T*	DL12S12E25R50S2-T*	DL12T12E25R50S2-T*
480				DL12F12M25R50S2-T*	DL12S12M25R50S2-T*	DL12T12M25R50S2-T*
240	13,500	28"		DL12F13.5E28R50S2-T*	DL12S13.5E28R50S2-T*	DL12T13.5E28R50S2-T*
480				DL12F13.5M28R50S2-T*	DL12S13.5M28R50S2-T*	DL12T13.5M28R50S2-T*
240	15,000	30"		DL12F15E30R50S2-T*	DL12S15E30R50S2-T*	DL12T15E30R50S2-T*
480				DL12F15M30R50S2-T*	DL12S15M30R50S2-T*	DL12T15M30R50S2-T*
240	18,000	35"		DL12F18E35R50S2-T*	DL12S18E35R50S2-T*	DL12T18E35R50S2-T*
480				DL12F18M35R50S2-T*	DL12S18M35R50S2-T*	DL12T18M35R50S2-T*

*Specify thermal protection desired, see page (48-49).
 Derated to 18 Watts per Square Inch Standard.
 Heater coded for 3-Phase. Single Phase option available at no extra charge.

Note: Additional wattages, voltages, and lengths available.

LV SERIES: IMMERSION HEATERS

The **LV Series** is a vertically stacked, L-shaped immersion heater designed to position heating elements along the sidewall and near the bottom of the tank. This configuration keeps the vertical working area clear while delivering high heat output at low liquid levels - ideal for demanding process applications where space and performance both matter.

Choose the LV Series when:

- The bottom of a tank must be unobstructed for part loading or racking
- Variable liquid levels rule out straight over-the-side heaters
- High kW density is required for rapid heat-up or elevating operating temperatures.

LV SERIES REFERENCE DIMENSIONS

Note: Dimensions will be identical for Derated heater models.

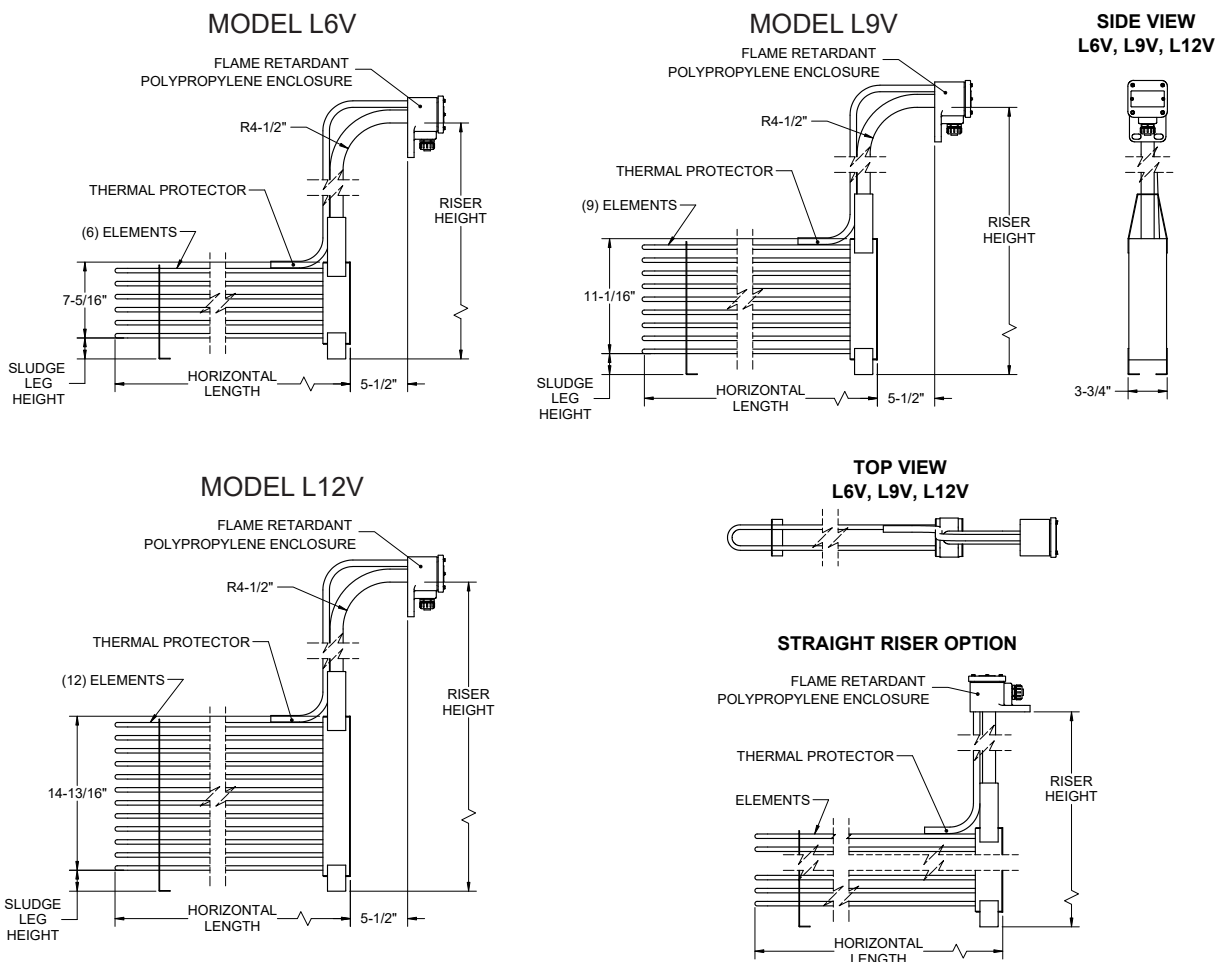

LV SERIES: IMMERSION HEATERS



L6V VERTICALLY STACKED L-SHAPE HEATERS						
SPECIFICATIONS				304 SS	316 SS	TITANIUM
Volts (3-PH)	Watts	Bottom Length	Vertical Height	Part Number	Part Number	Part Number
240	3,000	13"	37"	L6VF3E13R37S2-T*	L6VS3E13R37S2-T*	L6VT3E13R37S2-T*
480				L6VF3M13R37S2-T*	L6VS3M13R37S2-T*	L6VT3M13R37S2-T*
240	6,000	17"		L6VF6E17R37S2-T*	L6VS6E17R37S2-T*	L6VT6E17R37S2-T*
480				L6VF6M17R37S2-T*	L6VS6M17R37S2-T*	L6VT6M17R37S2-T*
240	9,000	22"		L6VF9E22R37S2-T*	L6VS9E22R37S2-T*	L6VT9E22R37S2-T*
480				L6VF9M22R37S2-T*	L6VS9M22R37S2-T*	L6VT9M22R37S2-T*
240	12,000	26"		L6VF12E26R37S2-T*	L6VS12E26R37S2-T*	L6VT12E26R37S2-T*
480				L6VF12M26R37S2-T*	L6VS12M26R37S2-T*	L6VT12M26R37S2-T*
240	15,000	31"		L6VF15E31R37S2-T*	L6VS15E31R37S2-T*	L6VT15E31R37S2-T*
480				L6VF15M31R37S2-T*	L6VS15M31R37S2-T*	L6VT15M31R37S2-T*
240	18,000	36"		L6VF18E36R50S2-T*	L6VS18E36R50S2-T*	L6VT18E36R50S2-T*
480				L6VF18M36R50S2-T*	L6VS18M36R50S2-T*	L6VT18M36R50S2-T*
480	21,000	40"	L6VF21M40R50S2-T*	L6VS21M40R50S2-T*	L6VT21M40R50S2-T*	
480	24,000	44"	L6VF24M44R50S2-T*	L6VS24M44R50S2-T*	L6VT24M44R50S2-T*	
480	27,000	50"	L6VF27M50R50S2-T*	L6VS27M50R50S2-T*	L6VT27M50R50S2-T*	
480	30,000	55"	L6VF30M55R50S2-T*	L6VS30M55R50S2-T*	L6VT30M55R50S2-T*	
480	36,000	64"	L6VF36M64R50S2-T*	L6VS36M64R50S2-T*	L6VT36M64R50S2-T*	

*Specify thermal protection desired, see page (48-49).
Heater coded for 3-Phase. Single Phase option available at no extra charge.

Note: Additional wattages, voltages, and lengths available.

LV SERIES: IMMERSION HEATERS



L9V VERTICALLY STACKED L-SHAPE HEATERS						
SPECIFICATIONS				304 SS	316 SS	TITANIUM
Volts (3-PH)	Watts	Bottom Length	Vertical Height	Part Number	Part Number	Part Number
240	6,000	12"	50"	L9VF6E12R50S2-T*	L9VS6E12R50S2-T*	L9VT6E12R50S2-T*
480				L9VF6M12R50S2-T*	L9VS6M12R50S2-T*	L9VT6M12R50S2-T*
240	9,000	15"		L9VF9E15R50S2-T*	L9VS9E15R50S2-T*	L9VT9E15R50S2-T*
480				L9VF9M15R50S2-T*	L9VS9M15R50S2-T*	L9VT9M15R50S2-T*
240	12,000	18"		L9VF12E18R50S2-T*	L9VS12E18R50S2-T*	L9VT12E18R50S2-T*
480				L9VF12M18R50S2-T*	L9VS12M18R50S2-T*	L9VT12M18R50S2-T*
240	15,000	22"		L9VF15E22R50S2-T*	L9VS15E22R50S2-T*	L9VT15E22R50S2-T*
480				L9VF15M22R50S2-T*	L9VS15M22R50S2-T*	L9VT15M22R50S2-T*
240	18,000	25"		L9VF18E25R50S2-T*	L9VS18E25R50S2-T*	L9VT18E25R50S2-T*
480				L9VF18M25R50S2-T*	L9VS18M25R50S2-T*	L9VT18M25R50S2-T*
480	21,000	29"		L9VF21M29R50S2-T*	L9VS21M29R50S2-T*	L9VT21M29R50S2-T*
480	24,000	32"		L9VF24M32R50S2-T*	L9VS24M32R50S2-T*	L9VT24M32R50S2-T*
480	27,000	36"		L9VF27M36R50S2-T*	L9VS27M36R50S2-T*	L9VT27M36R50S2-T*
480	30,000	39"		L9VF30M39R50S2-T*	L9VS30M39R50S2-T*	L9VT30M39R50S2-T*
480	36,000	55"		L9VF36M55R50S2-T*	L9VS36M55R50S2-T*	L9VT36M55R50S2-T*

*Specify thermal protection desired, see page (48-49).
Heater coded for 3-Phase. Single Phase option available at no extra charge.

Note: Additional wattages, voltages, and lengths available.

LV SERIES: IMMERSION HEATERS



L12V VERTICALLY STACKED L-SHAPE HEATERS						
SPECIFICATIONS				304 SS	316 SS	TITANIUM
Volts (3-PH)	Watts	Bottom Length	Vertical Height	Part Number	Part Number	Part Number
240	9,000	13"	50"	L12VF9E13R50S2-T*	L12VS9E13R50S2-T*	L12VT9E13R50S2-T*
480				L12VF9M13R50S2-T*	L12VS9M13R50S2-T*	L12VT9M13R50S2-T*
240	12,000	15"		L12VF12E15R50S2-T*	L12VS12E15R50S2-T*	L12VT12E15R50S2-T*
480				L12VF12M15R50S2-T*	L12VS12M15R50S2-T*	L12VT12M15R50S2-T*
240	15,000	18"		L12VF15E18R50S2-T*	L12VS15E18R50S2-T*	L12VT15E18R50S2-T*
480				L12VF15M18R50S2-T*	L12VS15M18R50S2-T*	L12VT15M18R50S2-T*
240	18,000	20"		L12VF18E20R50S2-T*	L12VS18E20R50S2-T*	L12VT18E20R50S2-T*
480				L12VF18M20R50S2-T*	L12VS18M20R50S2-T*	L12VT18M20R50S2-T*
480	21,000	23"		L12VF21M23R50S2-T*	L12VS21M23R50S2-T*	L12VT21M23R50S2-T*
480				L12VF24M26R50S2-T*	L12VS24M26R50S2-T*	L12VT24M26R50S2-T*
480	27,000	28"		L12VF27M28R50S2-T*	L12VS27M28R50S2-T*	L12VT27M28R50S2-T*
480				L12VF30M31R50S2-T*	L12VS30M31R50S2-T*	L12VT30M31R50S2-T*
480	36,000	40"		L12VF36M40R50S2-T*	L12VS36M40R50S2-T*	L12VT36M40R50S2-T*

*Specify thermal protection desired, see page (48-49).
 Heater coded for 3-Phase. Single Phase option available at no extra charge.

Note: Additional wattages, voltages, and lengths available.

F SERIES: IMMERSION HEATERS

The **F Series** flanged immersion heaters utilize ANSI pipe flange connections to deliver heat to water-based solutions or air/gas applications. These are typically installed horizontally into tank walls or into pipes with matching flange mating connections. Larger F Series heaters are well suited for delivering high kilowatt outputs to large process tanks, while consolidated element designs allow multiple heating elements to be combined into a single heater assembly saving cost.

Choose the F Series when:

- A permanent, sidewall mounted heater installation is required
- High kilowatt output is needed to heat large process volumes
- Multiple heating elements should be combined into a single assembly

F SERIES REFERENCE DIMENSIONS

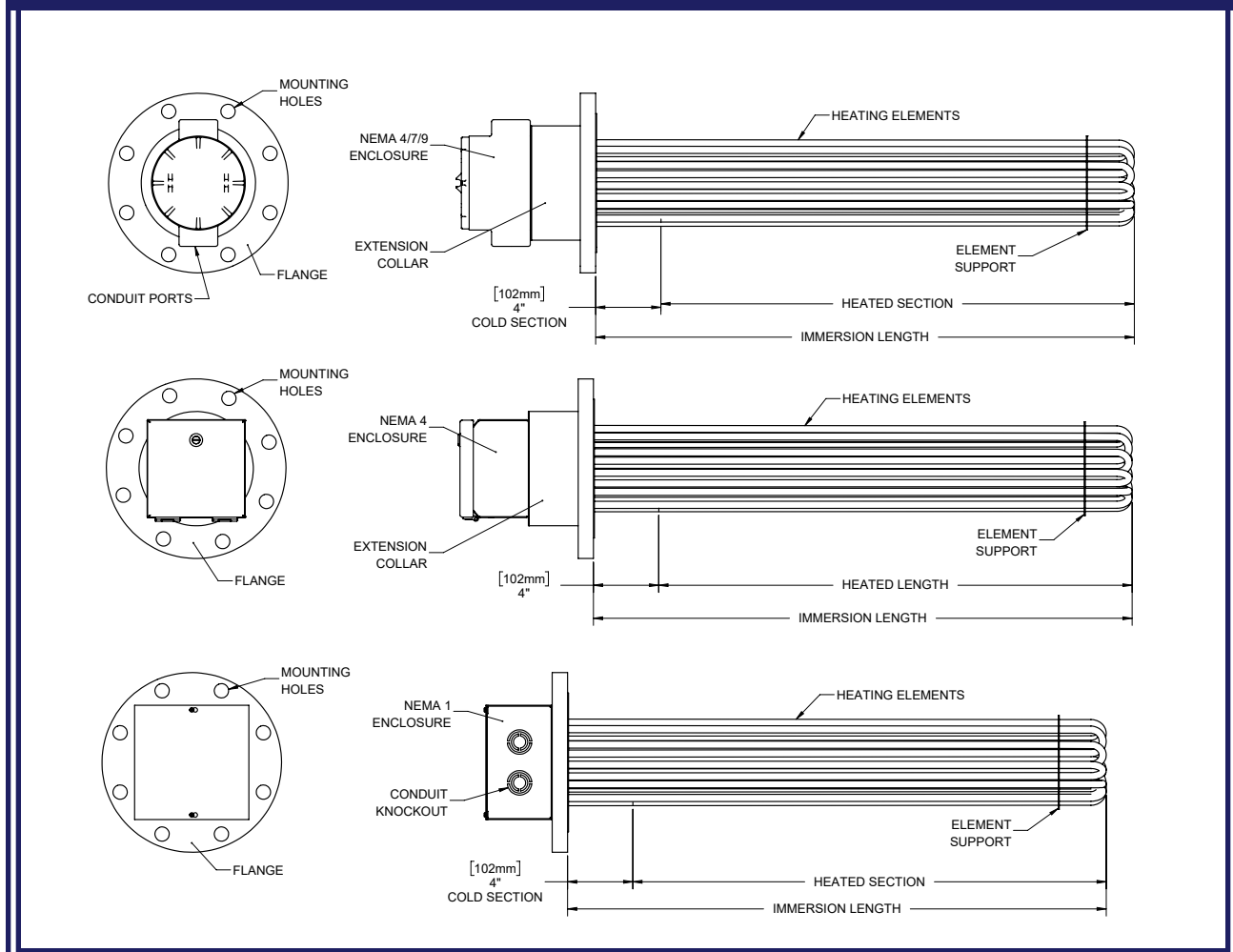

F SERIES: IMMERSION HEATERS



3" STEEL ANSI FLANGE HEATERS WITH STAINLESS STEEL ELEMENTS				
SPECIFICATIONS				PART NUMBER
Watts	Volts	Elements	Immersion	
3KW	240/480	3	9"	FH3AJ3S3M9-4-FAAAA
4.5KW	240/480	3	13"	FH3AJ3S4.5M13-4-FAAAA
6KW	240/480	3	19"	FH3AJ3S6M19-4-FAAAA
9KW	240/480	3	26"	FH3AJ3S9M26-4-FAAAA
12KW	240/480	3	33"	FH3AJ3S12M33-4-FAAAA
15KW	240/480	3	41"	FH3AJ3S15M41-4-FAAAA
18KW	240/480	3	49"	FH3AJ3S18M49-4-FAAAA

Part number coded for 480 Volt - 3 Phase. Coded for moisture resistant enclosures.

3" TITANIUM ANSI FLANGE HEATERS WITH TITANIUM ELEMENTS				
SPECIFICATIONS				PART NUMBER
Watts	Volts	Elements	Immersion	
3KW	240/480	3	9"	FH3AT3T3M9-4-FAAAA
4.5KW	240/480	3	13"	FH3AT3T4.5M13-4-FAAAA
6KW	240/480	3	19"	FH3AT3T6M19-4-FAAAA
9KW	240/480	3	26"	FH3AT3T9M26-4-FAAAA
12KW	240/480	3	33"	FH3AT3T12M33-4-FAAAA
15KW	240/480	3	41"	FH3AT3T15M41-4-FAAAA
18KW	240/480	3	49"	FH3AT3T18M49-4-FAAAA

Part number coded for 480 Volt - 3 Phase. Coded for moisture resistant enclosures.

Note: Additional wattages, voltages, lengths, and enclosures available.

F SERIES: IMMERSION HEATERS



4" STEEL ANSI FLANGE HEATERS WITH STAINLESS STEEL ELEMENTS				
SPECIFICATIONS				PART NUMBER
Watts	Volts	Elements	Immersion	
6KW	240/480	6	9"	FH4AJ6S6M9-4-GAAAA
9KW	240/480	6	13"	FH4AJ6S9M13-4-GAAAA
12KW	240/480	6	19"	FH4AJ6S12M19-4-GAAAA
18KW	240/480	6	26"	FH4AJ6S18M26-4-GAAAA
24KW	240/480	6	33"	FH4AJ6S24M33-4-GAAAA
30KW	240/480	6	41"	FH4AJ6S30M41-4-GAAAA
36KW	240/480	6	49"	FH4AJ6S36M49-4-GAAAA

Part number coded for 480 Volt - 3 Phase. Coded for moisture resistant enclosures.

4" TITANIUM ANSI FLANGE HEATERS WITH TITANIUM ELEMENTS				
SPECIFICATIONS				PART NUMBER
Watts	Volts	Elements	Immersion	
6KW	240/480	6	9"	FH4AT6T6M9-4-GAAAA
9KW	240/480	6	13"	FH4AT6T9M13-4-GAAAA
12KW	240/480	6	19"	FH4AT6T12M19-4-GAAAA
18KW	240/480	6	26"	FH4AT6T18M26-4-GAAAA
24KW	240/480	6	33"	FH4AT6T24M33-4-GAAAA
30KW	240/480	6	41"	FH4AT6T30M41-4-GAAAA
36KW	240/480	6	49"	FH4AT6T36M49-4-GAAAA

Part number coded for 480 Volt - 3 Phase. Coded for moisture resistant enclosures.

Note: Additional wattages, voltages, lengths, and enclosures available.

F SERIES: IMMERSION HEATERS



6" STEEL ANSI FLANGE HEATERS WITH STAINLESS STEEL ELEMENTS				
SPECIFICATIONS				PART NUMBER
Watts	Volts	Elements	Immersion	
12KW	240/480	12	9"	FH6AJ12S12M9-4-GAAAA
18KW	240/480	12	13"	FH6AJ12S18M13-4-GAAAA
24KW	240/480	12	19"	FH6AJ12S24M19-4-GAAAA
36KW	240/480	12	26"	FH6AJ12S36M26-4-GAAAA
48KW	240/480	12	33"	FH6AJ12S48M33-4-GAAAA
60KW	240/480	12	41"	FH6AJ12S60M41-4-GAAAA
72KW	240/480	12	49"	FH6AJ12S72M49-4-GAAAA

Part number coded for 480 Volt - 3 Phase. Coded for moisture resistant enclosures.

6" TITANIUM ANSI FLANGE HEATERS WITH TITANIUM ELEMENTS				
SPECIFICATIONS				PART NUMBER
Watts	Volts	Elements	Immersion	
12KW	240/480	12	9"	FH6AT12T12M9-4-GAAAA
18KW	240/480	12	13"	FH6AT12T18M13-4-GAAAA
24KW	240/480	12	19"	FH6AT12T24M19-4-GAAAA
36KW	240/480	12	26"	FH6AT12T36M26-4-GAAAA
48KW	240/480	12	33"	FH6AT12T48M33-4-GAAAA
60KW	240/480	12	41"	FH6AT12T60M41-4-GAAAA
72KW	240/480	12	49"	FH6AT12T72M49-4-GAAAA

Part number coded for 480 Volt - 3 Phase. Coded for moisture resistant enclosures.

Note: Additional wattages, voltages, lengths, and enclosures available.

For information on additional Heatmax products such as:



**Hastalloy
Flange
Heaters**



**Duct
Heaters**



**Custom
Heating
Elements**

Please visit www.heatmaxheaters.com

HEATMAX
HEATERS

R SERIES: SCREWPLUG HEATERS

R Series screw plug immersion heaters use NPT pipe thread connections to deliver reliable heating for water-based and compatible process solutions. These heaters are typically installed horizontally through tank walls or into piping using standard threaded connections. Their compact footprint and the cost-effectiveness of NPT fittings make the R series a practical, economical solution for heating small tanks, sumps, or confined spaces where larger heater styles are unnecessary.

Choose the R Series when:

- A threaded NPT connection is preferred over flanged or over-the-side mounting
- Tank or pipe space is limited and a compact heater design is required
- Heating requirements are moderate and localized.

R SERIES REFERENCE DIMENSIONS

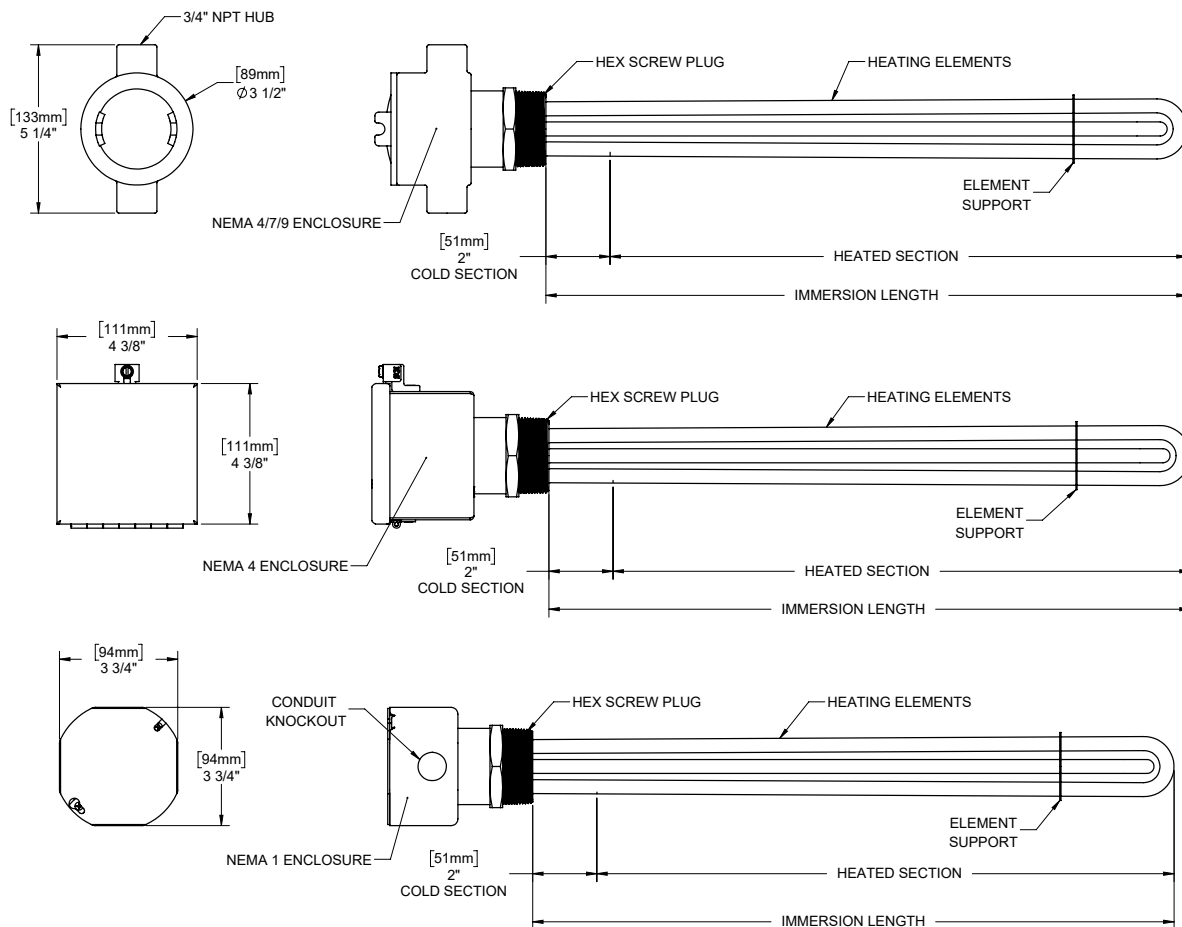

R SERIES: SCREWPLUG HEATERS

PRODUCT FEATURES

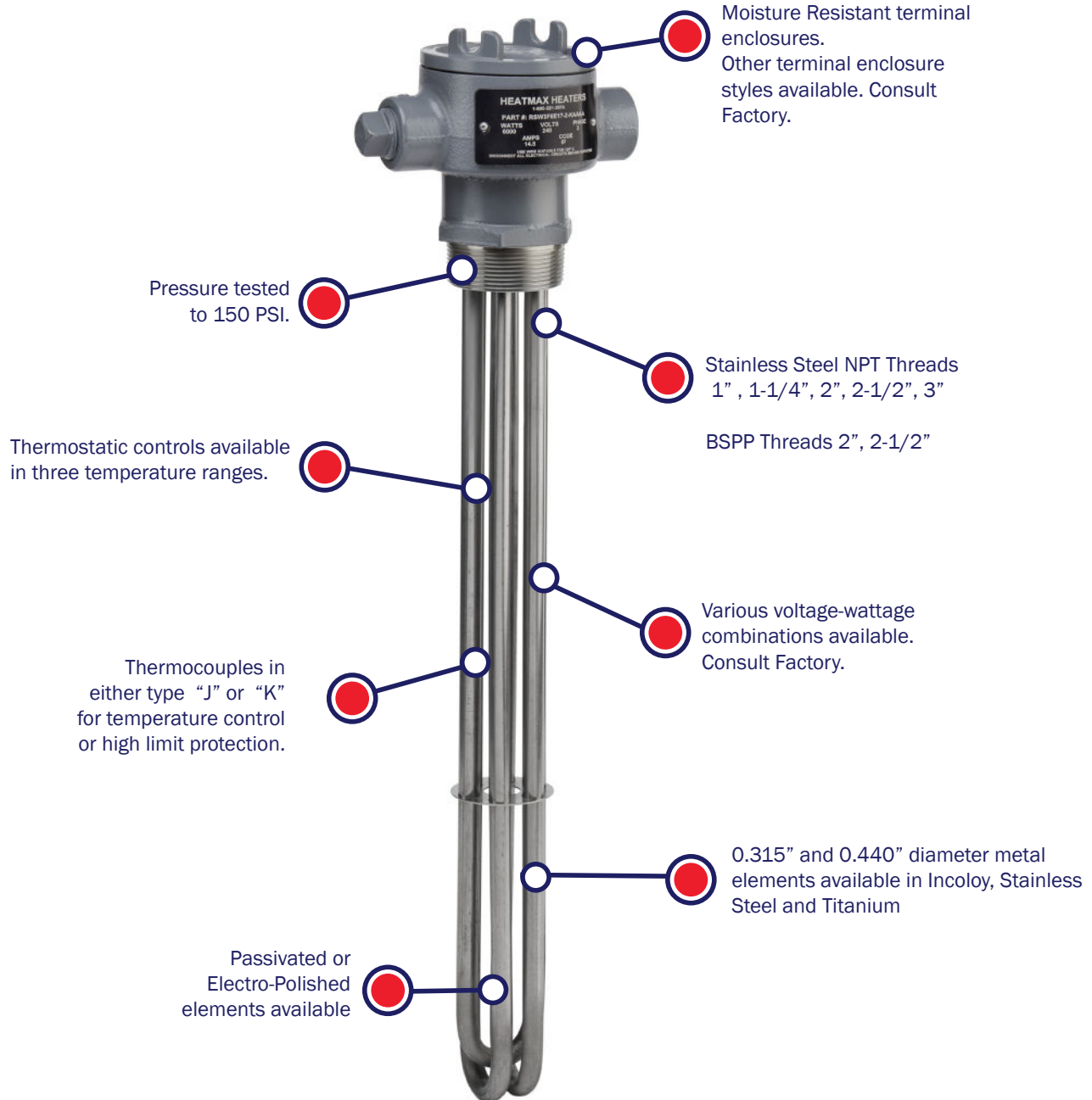

R SERIES: SCREWPLUG HEATERS



2" NPT STAINLESS STEEL SCREWPLUG WITH STAINLESS STEEL ELEMENTS				
SPECIFICATIONS				PART NUMBER
Watts	Volts	Elements	Immersion	
2,000	240/480	2	8"	RSW2S2MX8-2-FAAAA
3,000	240/480	2	12"	RSW2S3MX12-2-FAAAA
4,000	240/480	2	18"	RSW2S4MX18-2-FAAAA
6,000	240/480	2	25"	RSW2S6MX25-2-FAAAA
8,000	240/480	2	32"	RSW2S8MX32-2-FAAAA
10,000	240/480	2	40"	RSW2S10MX40-2-FAAAA
12,000	480	2	48"	RSW2S12MX48-2-FAAAA
15,000	480	2	54"	RSW2S15MX54-2-FAAAA

Part number coded for 480 Volt - Single Phase. Coded for moisture resistant enclosures.

2" NPT TITANIUM SCREWPLUG WITH TITANIUM ELEMENTS				
SPECIFICATIONS				PART NUMBER
Watts	Volts	Elements	Immersion	
2,000	240/480	2	8"	RSW2T2MX8-2-FAAAA
4,000	240/480	2	18"	RSW2T4MX18-2-FAAAA
6,000	240/480	2	25"	RSW2T6MX25-2-FAAAA
8,000	240/480	2	32"	RSW2T8MX32-2-FAAAA
12000	480	2	48"	RSW2T12MX48-2-FAAAA

Part number coded for 480 Volt - Single Phase. Coded for moisture resistant enclosures.

Note: Additional wattages, voltages, lengths, alloys, and enclosures available.

R SERIES: SCREWPLUG HEATERS



2" NPT STAINLESS STEEL SCREWPLUG WITH STAINLESS STEEL ELEMENTS				
SPECIFICATIONS				PART NUMBER
Watts	Volts	Elements	Immersion	
4,500	240/480	3	12"	RSX3S4.5M12-2-FAAAA
6,000	240/480	3	18"	RSX3S6M18-2-FAAAA
9,000	240/480	3	25"	RSX3S9M25-2-FAAAA
12,000	240/480	3	32"	RSX3S12M32-2-FAAAA
15,000	240/480	3	40"	RSX3S15M40-2-FAAAA
18,000	240/480	3	48"	RSX3S18M48-2-FAAAA
12,000	480	2	48"	RSW2S12M48-2-FAAAA
15,000	480	2	54"	RSW2S15M54-2-FAAAA

Part number coded for 480 Volt - 3 Phase. Coded for moisture resistant enclosures.

2" NPT TITANIUM SCREWPLUG WITH TITANIUM ELEMENTS				
SPECIFICATIONS				PART NUMBER
Watts	Volts	Elements	Immersion	
3,000	240/480	3	8"	RSW3T3M8-2-FAAAA
6,000	240/480	3	18"	RSW3T6M18-2-FAAAA
9,000	240/480	3	25"	RSW3T9M25-2-FAAAA
12,000	240/480	3	32"	RSW3T12M32-2-FAAAA
18,000	240/480	3	48"	RSW3T18M48-2-FAAAA

Part number coded for 480 Volt - 3 Phase. Coded for moisture resistant enclosures.

Note: Additional wattages, voltages, lengths, alloys, and enclosures available.

THERMAL PROTECTORS

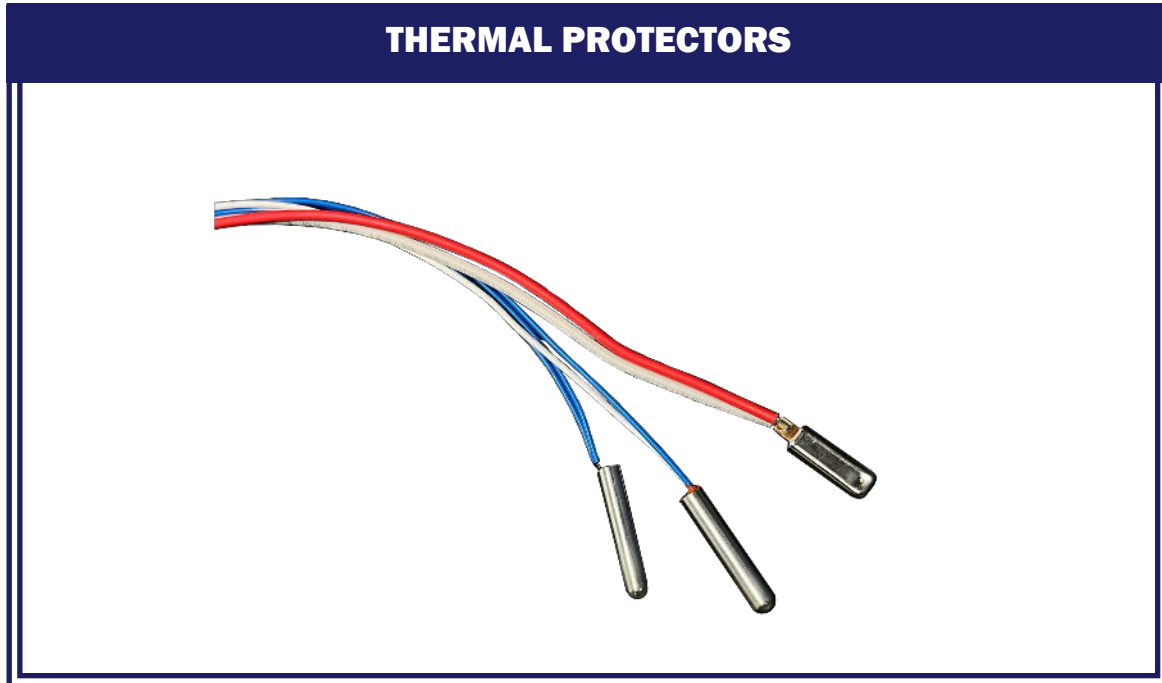

Thermal Protectors come standard with our over-the-side heaters and are provided either as a **Thermal Cut-off (TCO)**, **Bimetallic Thermostat** or **Thermocouple**. The protector is placed inside a thermowell positioned in contact with the heater sheath. When connected to a compatible combination control, the thermal protector will interrupt power to the heater upon sensing the preset high-limit temperature.

See the following page for thermal protector options and pricing.

THERMAL PROTECTORS

PROTECTOR TYPES

Protector A-Series (TCO)

The Protector A-Series utilizes a eutectic switch with a pre-specified internal organic pellet that experiences a phase change, allowing the spring activated contacts to permanently open the circuit. The TCO can alert operators to identify and remedy the cause of over temperature conditions when replacing the device. If the electrical rating permits, the TCO may be wired in series (direct connection) with the heater for economical installations. All three-phase installations or those where the heater power requirements exceed the amperage or voltage rating require a power contactor to provide an indirect heating load connection.

A-SERIES REPLACEABLE PROTECTOR (TCO)							
Style	Part Number	Wire Color	Wire Length	Process Temperature Range	Max Volts	Max Amps	Price
T1	59071-72-R	BLUE	72"	Up to 190°F (Up to 88°C)	240	15	\$57
T4	59072-72-R	WHITE / BLUE	72"	190°F to 230°F (88°C to 110°C)	240	15	
T5	59073-72-R	WHITE	72"	230°F to 300°F (110°C to 150°C)	240	15	

Protector B-Series (Bimetallic Thermostat)

The Protector B-Series has a pre-specified switching temperature that opens a circuit when the temperature exceeds its rating. The device must be connected to a controller with a power contactor (for an indirect heating load connection) and manual reset control circuitry. A manual push button reset feature allows the heater to be returned to operation if an over temperature or low liquid level event occurs. The heater must be inspected, and the cause of circuit interruption must be corrected before resetting the control circuitry.

B-SERIES RESETTABLE PROTECTOR (BIMETALLIC)							
Style	Part Number	Wire Color	Wire Length	Process Temperature Range	Max Volts	Max Amps	Price
T2	59069-72-R	RED / BLUE	72"	Up to 190°F (Up to 88°C)	120	2.6	\$57
T6	59070-72-R	RED / WHITE	72"	190°F to 230°F (88°C to 110°C)	120	2.6	
T7	59053-72-R	RED	72"	230°F to 300°F (110°C to 150°C)	120	2.6	

Protector C-Series (Thermocouple)

The Protector C-Series are thermocouple sensors that can be connected to external control circuitry. They are used for process temperature ranges up to 250°F (121°C).

C-SERIES PROTECTOR (THERMOCOUPLE)							
Style	Part Number	Thermocouple Type	Cable Color	Cable Length	Wire Color	Process Temperature Range	Price
T8	59078-72-R	J	BROWN	72"	RED / WHITE	Up to 250°F (Up to 121°C)	\$116
T9	59079-72-R	K	BROWN	72"	RED / YELLOW	Up to 250°F (Up to 121°C)	

DO NOT wire B-Series or C-Series protectors directly to power the heater. A short circuit will result and cause irreparable damage to the heater.

DIGITAL COMBINATION CONTROLS

The **TCD Digital Combination Control** is a compact, integrated, and cost-effective solution for safely operating SW, TF, and L Series immersion heaters. Equipped with a 10-ft FEP sleeved thermocouple and an LED digital temperature controller, the TCD Series provides precise temperature regulation for open-topped tanks. This is combined with a terminal block for connecting any heater's built-in replaceable or resettable hi-limit thermal protector (standard on our SW, TF, and L Series products), an essential safeguard in metal finishing applications.

TCD SERIES CONTROL REFERENCE DIMENSIONS

Control Type	-	Version	Voltage	Amperage	-	Standard Options
TCD	-	3	1 - 120	30	-	Blank = Standard options, 10 ft. Thermocouple
			2 - 208	50		## = Custom Length FEP protected Type "J" Thermocouple
			2 - 220	70		N4XSS = Nema 4X, 12" x 12" x 6" Stainless Enclosure
			2 - 240	90		XXXX = Custom drawing extension
			3 - 380	135		
			5 - 415			
			4 - 440			
			4 - 460			
			4 - 480			
			6 - 600			

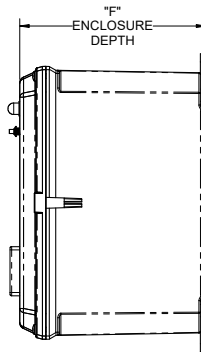
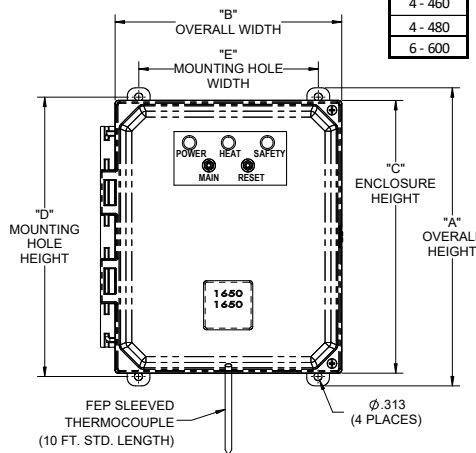

Dimensions	30-70 Amps	90-135 Amps
- Nominal Size	10" x 8" x 6"	12" x 10" x 6"
A Overall Height	12.07" (307mm)	13.69" (348mm)
B Overall Width	8.53" (217mm)	10.54" (268mm)
C Enclosure Height	10.54" (268mm)	12.54" (318mm)
D Mounting Hole Height	11.13" (283mm)	13.13" (334mm)
E Mounting Hole Width	5.63" (143mm)	7.63" (194mm)
F Enclosure Depth	7.47" (190mm)	7.47" (190mm)

DUAL SET POINT DIGITAL TEMPERATURE COMBINATION CONTROLS (240 VOLT)

Part Number	Description
TCD-3230	COMBINATION CONTROL, 30AMP CAPACITY, 240V-1/3
TCD-3250	COMBINATION CONTROL, 50AMP CAPACITY, 240V-1/3
TCD-3270	COMBINATION CONTROL, 70AMP CAPACITY, 240V-1/3
TCD-3290	COMBINATION CONTROL, 90AMP CAPACITY, 240V-1/3
TCD-32135	COMBINATION CONTROL, 120AMP CAPACITY, 240V-1/3

DUAL SET POINT DIGITAL TEMPERATURE COMBINATION CONTROLS (480 VOLT)

Part Number	Description
TCD-3430	COMBINATION CONTROL, 30AMP CAPACITY, 480V-1/3
TCD-3450	COMBINATION CONTROL, 50AMP CAPACITY, 480V-1/3
TCD-3470	COMBINATION CONTROL, 70AMP CAPACITY, 480V-1/3
TCD-3490	COMBINATION CONTROL, 90AMP CAPACITY, 480V-1/3
TCD-34135	COMBINATION CONTROL, 120AMP CAPACITY, 480V-1/3

Note: Built in timer, or longer length thermocouples are available.

DIGITAL COMBINATION CONTROLS

PRODUCT FEATURES

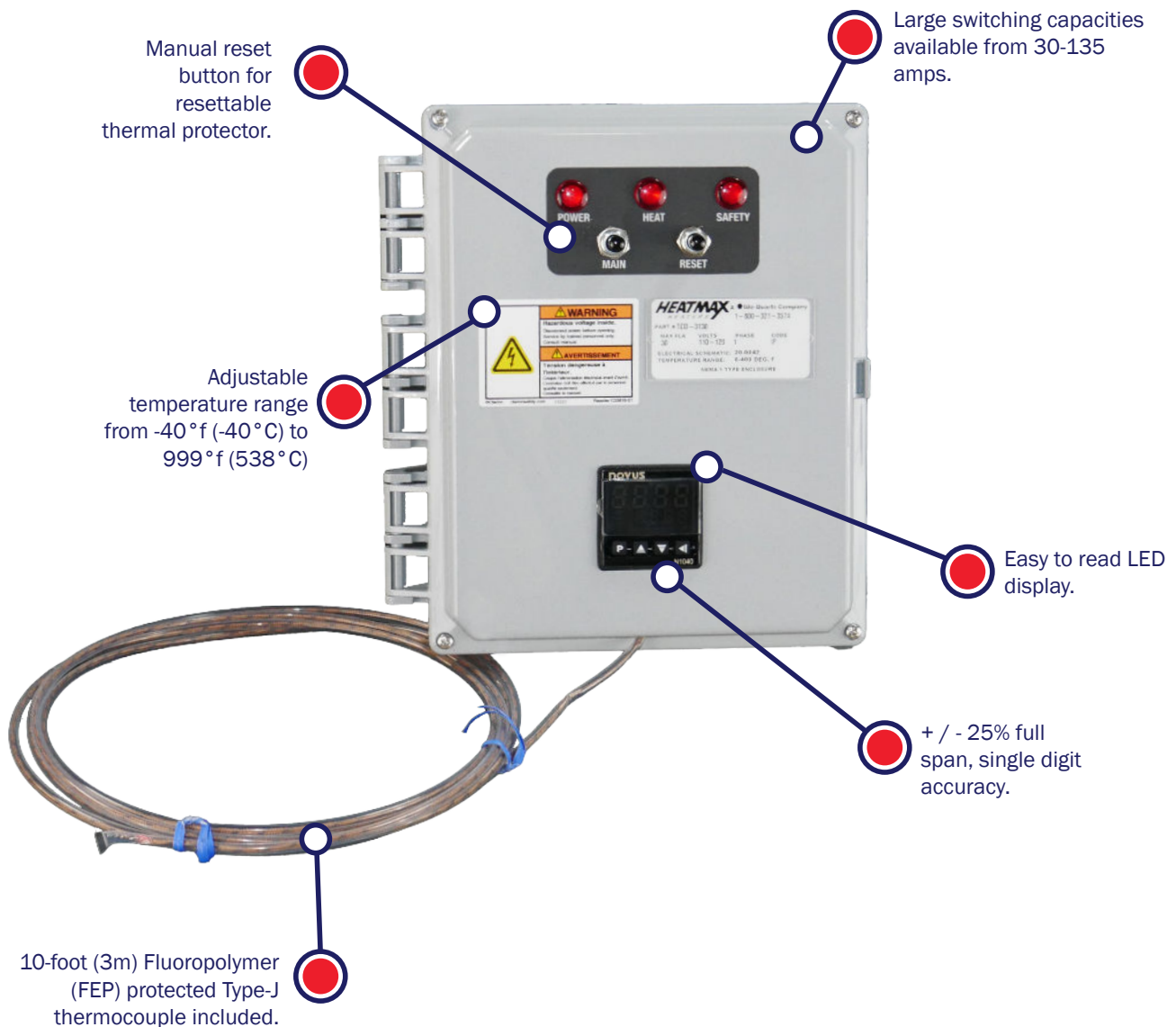

LIQUID LEVEL CONTROLS

The **Liquid Level Control** is an external safety module designed to integrate with the TCD control and interrupt power to electric immersion heaters if liquid levels fall below safe operating limits. This control provides automatic, fail-safe protection and is essential for the safe operation of electric immersion heaters in polypropylene and other non-metallic tanks. When paired with a **Remote Probe Assembly** - available in multiple lengths and alloy options - the Liquid Level Control can be configured to match specific tank geometries, liquid levels, and chemical compatibility requirements.

LIQUID LEVEL CONTROL	
Part Number	Description
LLC-R	SINGLE LEVEL CONTROL, 120/240V

REMOTE PROBE ASSEMBLIES	
Part Number	Description
PGR-6	GRAPHITE, 6" DUAL PROBES
PGR-12	GRAPHITE, 12" DUAL PROBES
PGR-18	GRAPHITE, 18" DUAL PROBES
PTR-6	TITANIUM, 6" DUAL PROBES
PTR-12	TITANIUM, 12" DUAL PROBES
PTR-18	TITANIUM, 18" DUAL PROBES
PSR-6	STAINLESS, 6" DUAL PROBES
PSR-12	STAINLESS, 12" DUAL PROBES
PSR-18	STAINLESS, 18" DUAL PROBES
PSR-24	STAINLESS, 24" DUAL PROBES

Stainless Steel and Titanium probes are field trimmable.
Graphite probes are not. Other lengths available.

LIQUID LEVEL CONTROLS

REMOTE MOUNTED LIQUID LEVEL CONTROL

REMOTE MOUNTED PROBES

PRODUCT FEATURES

Adds protection against low solution levels and the damage that can result.



Automated control of liquid levels for conductive solutions.

Double probe units provide single point controls.



Polycarbonate enclosure NEMA 4X 6" x 6" x 4" clearance.

Note:

Do not use in flammable solutions or in the presence of flammable gasses.

Does not function in non-conductive solutions such as oil or deionized water.

LIQUID LEVEL CONTROLS

PTR AND PSR REMOTE MOUNTED PROBE ASSEMBLY

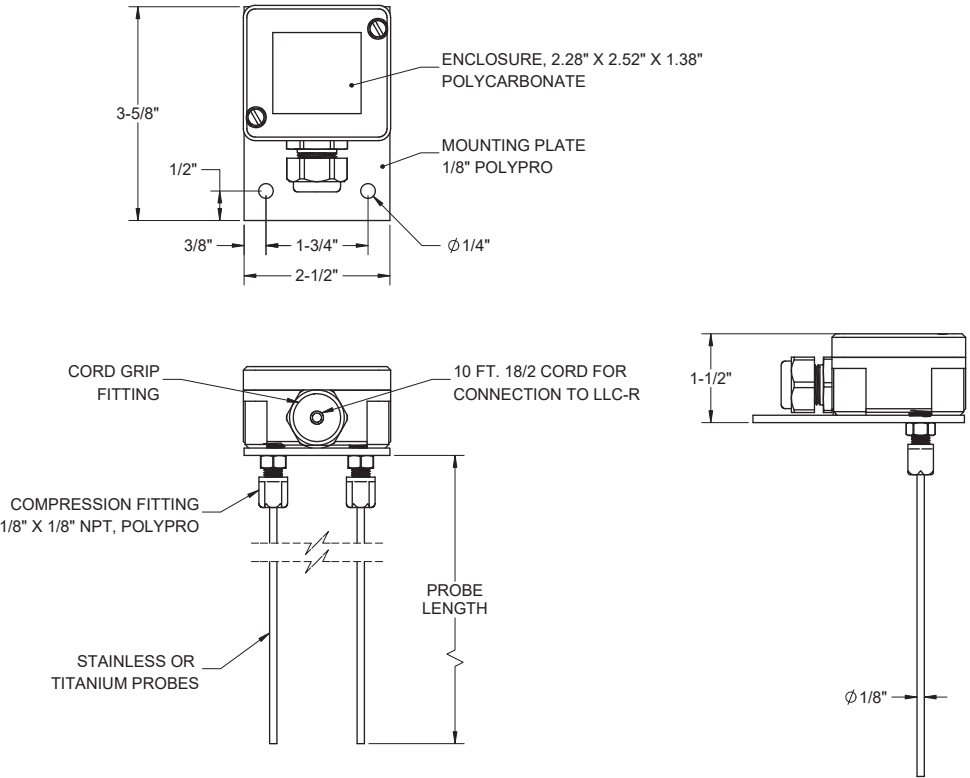

LIQUID LEVEL CONTROLS

PGR REMOTE MOUNTED PROBE ASSEMBLY

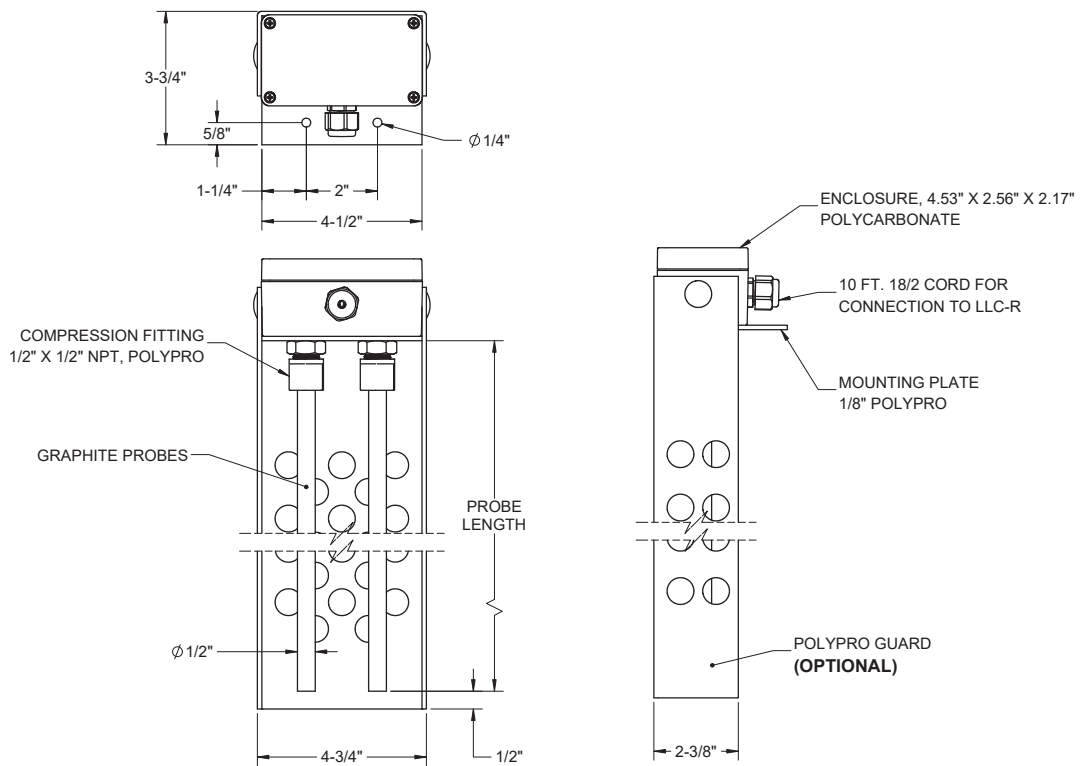

CONTROL ACCESSORIES

REPLACEMENT SENSORS AND THERMOWELLS



TCD CONTROL REPLACEMENT SENSOR GUIDE

Part Number	Description	Control Model	List Price
TJX-6	6 FOOT FEP SLEEVED THERMOCOUPLE	TCD	\$54
TJX-10	10 FOOT FEP SLEEVED THERMOCOUPLE		\$72
TJX-20	20 FOOT FEP SLEEVED THERMOCOUPLE		\$97

OVER THE SIDE THERMOWELLS

Part Number	Description	Material	List Price
TOSS-12	12" LONG 1/2" DIAMETER THERMOWELL	316 Stainless	\$65
TOSS-24	24" LONG 1/2" DIAMETER THERMOWELL	316 Stainless	\$83
TOSS-36	36" LONG 1/2" DIAMETER THERMOWELL	316 Stainless	\$91
TOT-12	12" LONG 1/2" DIAMETER THERMOWELL	Titanium	\$83
TOT-24	24" LONG 1/2" DIAMETER THERMOWELL	Titanium	\$106
TOT-36	36" LONG 1/2" DIAMETER THERMOWELL	Titanium	\$114

THERMOWELLS WITH 3/8" NPT FITTING

Part Number	Description	Material	List Price
TWSS-12	12" LONG 1/2" DIAMETER THERMOWELL	316 Stainless	\$121
TWSS-24	24" LONG 1/2" DIAMETER THERMOWELL	316 Stainless	\$125
TWSS-36	36" LONG 1/2" DIAMETER THERMOWELL	316 Stainless	\$133
TWT-12	12" LONG 1/2" DIAMETER THERMOWELL	Titanium	\$264
TWT-24	24" LONG 1/2" DIAMETER THERMOWELL	Titanium	\$287
TWT-236	36" LONG 1/2" DIAMETER THERMOWELL	Titanium	\$407

CONTROL ACCESSORIES

OVER-THE-SIDE THERMOWELL DRAWING

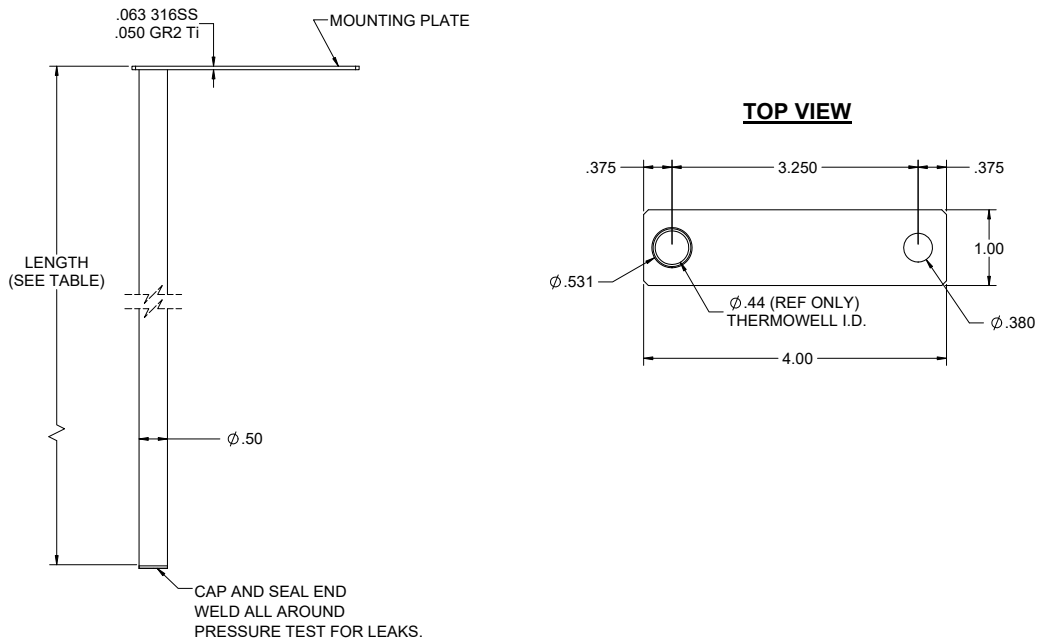

NPT THERMOWELL DRAWING

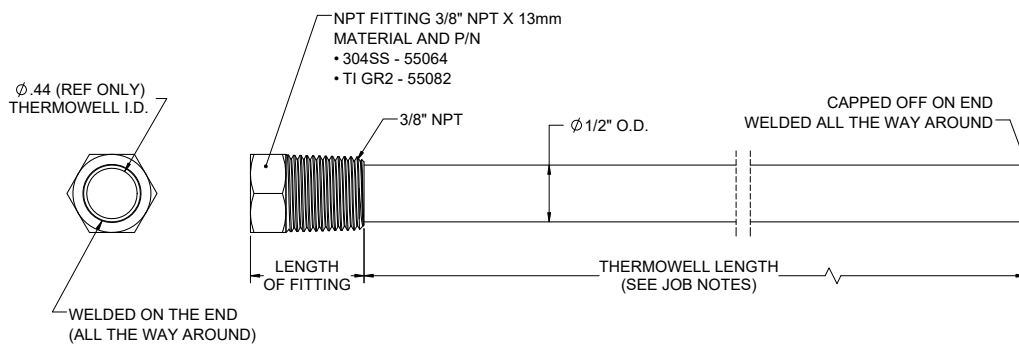

CHEMICAL COMPATIBILITY GUIDE

**THE DATA LISTED IS PROVIDED GRATIS AND IS OFFERED AS A GUIDE ONLY.
IT IS NOT INTENDED TO BE USED AS THE SOLE BASIS OF DESIGN OR TO ESTABLISH SPECIFICATION LIMITS. HEATMAX HEATERS
ASSUMES NO OBLIGATION OR LIABILITY FOR ANY ADVICE FURNISHED BY IT OR FOR RESULTS OBTAINED FROM USE.**

Acetic Acid.....	Titanium, or PTFE*	Chloride	PTFE* or Titanium
Acetic Anhydride (<180°F).....	Titanium, or PTFE*	Chlorosulfuric Acid	Titanium
Actane 70, 80	PTFE*	Chromic Anodizing	PTFE*
Actane Salt	PTFE*	Chromic Acetate	PTFE*
Acid Sulfate	PTFE*	Chromic Nickel	PTFE*
Alcorite	PTFE*	Chromium (No Fluorides)	PTFE* or Titanium
Alkaline Cleaners (Electrified).....	304 Stainless Steel	Chromium (Fluoride)	PTFE*
Alkaline Soaking Cleaners.....	304 Stainless Steel	Non-Hexavalent Chromate (No Fluorides).....	PTFE* or Titanium
Alodine (most formulas).....	316 Stainless Steel	Non-Hexavalent Chromate (Fluorides).....	PTFE*
Alstan	304 Stainless Steel	Citric Acid	Titanium
Aluminum Bright Dip.....	PTFE*	Clear Chromate	PTFE*
Aluminum Cleaners.....	Derated 304 Stainless Steel	Cobalt Nickel	PTFE* or Titanium
Aluminum Chloride.....	PTFE*	Cobalt Plating	304 Stainless Steel
Aluminum Sulfate	304 Stainless Steel	Cobra Etch	PTFE*
Aluminum Acetate.....	Derated 316 Stainless Steel or Titanium	Copper Acid	PTFE*
Aluminum Anodizing.....	PTFE*	Copper Bright Acid	PTFE*
Ammonia	Derated 304 Stainless Steel	Copper Cyanide	304 Stainless Steel
Ammonium Acetate.....	316 Stainless Steel	Copper Fluoborate	PTFE*
Ammonia Persulfate	PTFE*	Copper Pyrophosphate	304 Stainless Steel
Ammonium Bi Fluoride.....	PTFE*	Copper Strike	304 Stainless Steel
Ammonium Chloride	Titanium	Copper Sulfate	PTFE*
Ammonium Nitrate	316 Stainless Steel	Cyanide	304 Stainless Steel
Anodizing	PTFE*	Degreasing Solutions (vapor).....	Derated 316 Stainless Steel
ARP 28, 80 Blackening Salts.....	PTFE*	Deionized Water.....	316 Stainless Steel or Titanium
Arsenic	304 Stainless Steel	Deoxidizer (Etching)	PTFE*
Barium Chloride.....	316 Stainless Steel or Titanium	Deoxidizer Non-Chromated	316 Stainless Steel
Benzoic Acid	Titanium or PTFE*	Dichromic Seal	304 Stainless Steel
Black Nickel	PTFE*	Diethylene Glycol	304 Stainless Steel
Black Oxide (Hi-Temp) ...	Derated 316 Stainless Steel	Diversey, 511, 514	PTFE*
Black Oxide (Low-Temp)	Titanium	Dow Therm	Derated 316 Stainless Steel
Bleach (Sodium Hypochlorite).....	Titanium or PTFE*	Dye Solutions	304 Stainless Steel
Bonderizing	Derated 316 Stainless Steel	Ebonal C	Titanium
Boric Acid	Titanium	Electroless Copper	PTFE*
Brass Cyanide	304 Stainless Steel	Electroless Nickel	PTFE* or Derated Titanium
Bright Nickel	PTFE* or Titanium	Electroless Tin (Acid)	PTFE*
Bright Copper Cyanide	304 Stainless Steel	Electroless Tin (Alkaline)	316 Stainless Steel
Bronze (Alkaline).....	304 Stainless Steel	Electro Cleaner	304 Stainless Steel
Brown Oxide	Titanium	Electro Polishing	PTFE*
Burnite	PTFE*	Enthone 80 Acid	PTFE*
Butyric Acid	Titanium	Ethylene Glycol	Derated 304 Stainless Steel
Cadmium Black	PTFE*	Fatty Acids	Derated 316 Stainless Steel
Cadmium (Alkaline)	304 Stainless Steel	Ferric Ammonium Oxide	316 Stainless Steel
Cadmium Fluoborate	PTFE*	Ferric Chloride	PTFE* or Titanium
Calcium Chloride	Titanium	Ferric Nitrate	304 Stainless Steel
Calcium Hydroxide (dilute).....	316 Stainless Steel	Ferric Sulfate	304 Stainless Steel
Calcium Hydroxide (concentrated).....	PTFE*	Fluoborate	PTFE*
Calcium Hypochlorite	Titanium	Formic Acid	316 Stainless Steel
Carbonic Acid	Titanium	Glycerol	Derated 304 Stainless Steel
Caustic Etch	Derated 304 Stainless Steel	Immersion Gold	304 Stainless Steel
Caustics	304 Stainless Steel	Gold-Acid	PTFE* or Titanium
Caustics (highly concentrated 20% and over)...	Derated 304 Stainless Steel	Gold Cyanide	304 Stainless Steel
Chlorine/Wet	PTFE*	Grey Nickel	PTFE* or Titanium

Hot Seal Dichromate	316 Stainless Steel	Silver Cyanide	304 Stainless Steel
Hydrochloric Acid	PTFE*	Silver Lume	304 Stainless Steel
Hydrofluoric Acid	PTFE*	Silver Nitrate	316 Stainless Steel
Hydrogen Peroxide	PTFE*	Sodium Bisulfate	PTFE*
Indium	PTFE*	Sodium Carbonate	Titanium
Iridite (4-75,4-73,14,14-2,14-9).....	316 Stainless Steel	Sodium Chlorate	Titanium
Iridite (1,2,3,4-C, 7, 8,15).....	PTFE*	Sodium Chloride	Incoloy 800 or Titanium
Iron Fluoborate	PTFE*	Sodium Cyanide	304 Stainless Steel
Iron Phosphate	Sodium Dichromate (Hot Seal)	316 Stainless Steel
Derated 316 Stainless Steel or Incoloy 800		Sodium Hydroxide	304 Stainless Steel
Isoprep (186,187,188)	316 Stainless Steel	Sodium Hydroxide (concentrated).....	Derated 304 Stainless Steel
Isoprep Acid Salts	PTFE*	Sodium Hypochlorite	Titanium or PTFE*
Jetal	304 Stainless Steel	Sodium Persulfate	PTFE*
Lactic Acid	Derated 316 Stainless Steel, or PTFE*	Sodium Nitrate.....	Incoloy 800 or PTFE*
Lead Acetate	Incoloy 800	Stannate	304 Stainless Steel
Lime Saturated Water (Alkaline).....	Derated 316 Stainless Steel	Stanic Chloride.....	PTFE*
Lye (Caustic).....	316 Stainless Steel or PTFE	Stanostar	PTFE*
Linseed Oil	304 Stainless Steel	Sulfamate Nickel	PTFE* or Titanium
Manganese Chloride.....	PTFE*	Sulfur	PTFE*
Magnesium Hydroxide ...	Derated 304 Stainless Steel	Sulfur Peroxide	PTFE*
Magnesium Nitrate	PTFE*	Sulfuric Acid	PTFE*
Manganese Phosphate	Sulphamic Acid	PTFE*
Derated 316 Stainless Steel or Incoloy 800		Tannic Acid	Titanium
McDermid 629	PTFE*	Tin Nickel	PTFE*
Mercuric Chloride	Titanium	Tin Plating (Acid)(Stanus/Sulphate)	PTFE*
Methane Sulfonic Acid.....	PTFE*	Tin Plating Acid (Fluoborate)	PTFE*
Molten Salt Bath.....	Incoloy 800	Tin Plating (Alkaline)	304 Stainless Steel
Muriatic Acid	PTFE*	Trichlorethylene	316 Stainless Steel
Nickel (Plating Solution) (Watts)....	PTFE* or Titanium	Trioxide (Pickle)	PTFE*
Nickel Acetate Seal	316 Stainless Steel	Turco (4181, 4338)	316 Stainless Steel
Nickel Chloride	Titanium	Unichrome	PTFE*
Nitric Acid	PTFE*	Water	316 Stainless Steel
Nitric Hydrochloric Acids	PTFE*	Wood's Nickel Strike	PTFE* or Titanium
Nitric & (6%) Phosphoric	PTFE*	Yellow Dichromate	PTFE*
Derated 316 Stainless Steel or Incoloy 800		Zinc Acid	PTFE* or Titanium
Oil	Derated 304 Stainless Steel	Zinc Ammonium Chloride	Titanium
Oleic Acid	PTFE*	Zinc Cyanide	304 Stainless Steel
Oxalic Acid	PTFE*	Zinc Phosphate	Derated 316 Stainless Steel or Incoloy 800 / Check SDS
Paint Stripper (Alkaline)	316 Stainless Steel	Zinc Phosphate (Fluoride).....	PTFE* / Check SDS
Paint Stripper (with Solvent or high PH)	Derated 316 Stainless Steel	Zinc Sulfate.....	316 Stainless Steel
Perchloryethylene	Derated 316 Stainless Steel	Zincate	304 Stainless Steel
Phosphoric Acid (No Fluoride)	PTFE*		
Phosphate Cleaner.....	Derated 304 Stainless Steel		
Phosphate	Derated 316 Stainless Steel		
Potassium Acid Sulfate	PTFE*		
Potassium Cyanide	304 Stainless Steel		
Potassium Hydroxide		
Derated 316 Stainless Steel or Incoloy 800			
Potassium Hydrochloric	PTFE*		
Potassium Permanganate		
	PTFE* or Derated Titanium		
Rhodium	PTFE*		
Rochelle Salt Cyanide	304 Stainless Steel		
Ruthenium Plating.....	PTFE*		
Salt (Actine)	PTFE*		
Sea Water	Titanium		
Salt Water/Brine.....	Titanium		
Silver Bromide	316 Stainless Steel		

DUE TO THE COMPLEXITIES OF SOLUTIONS AND APPLICATIONS, IT IS THE CUSTOMER'S RESPONSIBILITY TO CONTACT THEIR CHEMICAL SUPPLIER FOR HEATER MATERIAL COMPATIBILITY AND RECOMMENDATIONS. PLEASE ENSURE APPLICABILITY OF HEATER BEFORE INSTALLATION SINCE WE CANNOT GUARANTEE HEATERS AGAINST PREMATURE FAILURE DUE TO CORROSION OR CHEMICAL DESTRUCTION CAUSED BY UNUSUAL CONDITIONS OVER WHICH WE HAVE NO CONTROL, SUCH AS:

- | | |
|--|--|
| ! Excessively high solution temperatures. | ! Excessive sludge build-up. |
| ! The concentration of the solution. | ! Stagnant or turbulent flow of the solution. |
| ! The presence of inhibitors. | ! Aeration. |
| ! The presence of other acids causing a secondary reaction. | ! Presence of oxygen or an oxidizing agent in the solution. |
| ! Stray electrical currents. | ! Erosion. |
| ! Flux floating on the surface. | ! High pressures. |
| ! The presence of dissolved gases. | ! Vacuum conditions. |

* PTFE is a polytetrafluoroethylene fluoropolymer.

WARRANTY AND RETURNS

Warranty Coverage

Heatmax warrants its electric immersion heaters and controls to be free from defects in materials and workmanship under normal use and service. Unless otherwise stated, heaters are warranted for **twelve (12) months from the date of shipment.**

This warranty applies only when products are:

- Properly specified for the application
- Installed and operated in accordance with Heatmax recommendations
- Used within material, electrical, and temperature limits

At its discretion, Heatmax will repair or replace any product found to be defective during the warranty period.

Warranty Exclusions

This warranty does **not** cover failures resulting from:

- Improper application or incorrect material selection
- Exposure to incompatible or undisclosed chemicals or higher concentrations
- Operation above rated voltage, or temperature limits
- Dry firing, low liquid level operation, or insufficient liquid coverage
- Improper installation, wiring, or maintenance
- Normal wear, corrosion, scaling, or buildup associated with the process solution

Heatmax is not responsible for consequential damages, downtime, or labor costs associated with removal or installation.

Return Policy

Most Heatmax products are built to order and are not returnable without prior authorization.

- All returns require a Return Material Authorization (RMA) number issued by Heatmax.
- Unauthorized returns will not be accepted.
- Custom or modified heaters are generally non-returnable.

Warranty Evaluation and RMA Process

If a heater or control is suspected to be defective:

1. Contact Heatmax with the part number, serial number, and application details
2. Basic troubleshooting may be required prior to return authorization
3. If approved, an RMA number and return instructions will be provided

No material should be returned without an RMA number clearly marked on the shipment.

Freight & Liability

Products returned for warranty evaluations must be shipped freight prepaid unless otherwise authorized. Heatmax assumes no responsibility for damage incurred during transit.

Contact & Support

Heatmax electric immersion heaters are sold through authorized distributors and OEM partners.

For pricing, lead times, and ordering, please contact your Heatmax supplier.

For application support, safety questions, or warranty evaluation, Heatmax technical assistance is available to support both customers and authorized partners.

Heatmax Heaters

Mentor, Ohio, USA

Technical Support & Product Information:

www.heatmaxheaters.com/contact/



Heatmax 2026 Priced Catalog Revision B

Updated 2.6.26